



S93/S87

ADVANCED HEAT EXCHANGERS

- The new Onda brazed plates S93 and S87 have been developed to respond to high efficiency and low water pressure drop market demand using high pressure refrigerants as R454B, R32 and R410A
- The design of the plate corrugation pattern has been optimized thanks to a CFD analysis supported by thermal laboratory test
- New patented distribution system which allows to achieve stable performance with large plate package

BENEFITS VS S82

- Evaporator and condenser average performance: +30% kW/m²
- Lower DP_{water} -25% at same flow rate
- Stainless steel average weight saving : -20%

CONFIGURATION

- Capacity range 20 – 90 kW
- Two model range PS 30 barg, PS 45 barg
- S93 asymmetric channels
- S87 symmetric channels

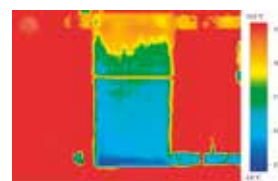

THERMAL LABORATORY TEST

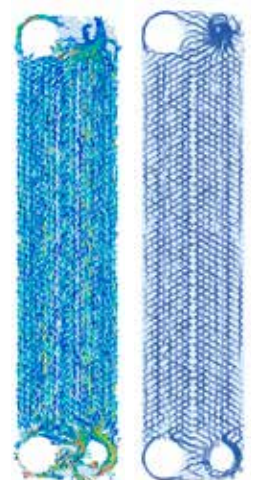

CFD ANALYSIS

BRAZED PLATE

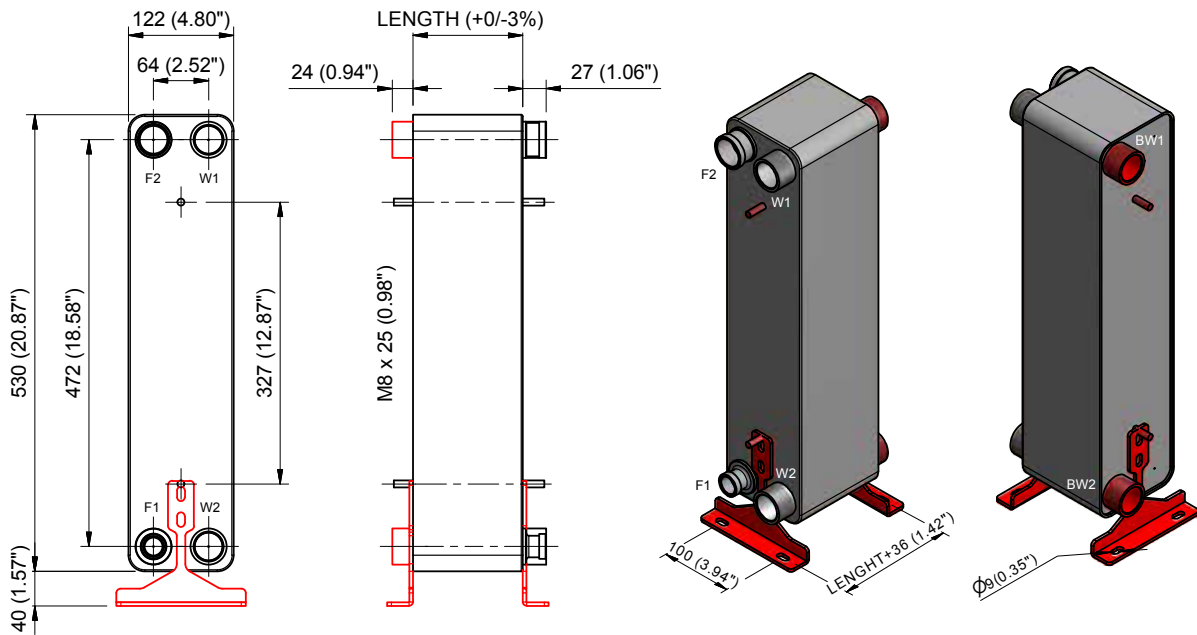

Optional: stud bolts and mounting feet

F1 INLET Refrigerant W1-BW1 INLET Secondary Fluid
 F2 OUTLET Refrigerant W2-BW2 OUTLET Secondary Fluid

SPECIFICATIONS	S87_S93	S87H_S93H
PS (bar)	30	45
TEMPERATURE RANGE (°C)	-100°C to +120°C	-100°C to +120°C
MAXIMUM CONNECTIONS AVAILABLE (mm)	38,9	38,9
MAXIMUM FLOW RATE (m3/h)	23,6	23,6
VOLUME / CHANNEL (liters)	0,122	0,122
DIMENSIONS (mm)	122 x 530	122 x 530
LENGHT CALCULATION (mm)	N x 2,15 + 11	N x 2,15 + 15
WEIGHT CALCULATION (kg)	N x 0,17 + 2	N x 0,17 + 6

CONNECTIONS TYPE				
Soldering	Threaded M	Threaded F	Grooved	Rotalock
S6	C22	F22	V32	R19
S8	IC22	F27	BV32	R25
S12	C27	F32	V40	R32
S14	IC27	F42	BV40	R44
S16	C32	IF22		
S18	IC32	IF27		
S19	C42	IF32		
S22	IC42	IF42		
S28	G22			
S35	G27			
	G32			
	G42			

Standard Connections:
 F1 S16 F2 S35 W1-W2 C42

N Number of plates

LETTER TO IDENTIFY CONNECTIONS TYPE

- S** Soldering Connections
- C** Conical Male Gas Threaded Connections
- G** Cylindric Male Gas Threaded Connections
- F** Female Gas Threaded Connections
- V-BV** Grooved System for Standard Flexible Coupling
- R** Rotalock Connections Male

EXCHANGE PLATE MATERIAL Stainless Steel 316L

BRAZING MATERIAL Copper (Cu)

To optimize the evaporator S87D-S87HD / S93D-S93HD performance refer to Onda' software HTC Brazed - nozzles at additional accessories page

ONDA S.p.A.

onda@onda-it.com - www.onda-it.com

PLANT 1 Headquarters
 Via Dante Alighieri, 27B
 36065 Mussolente (VI)
 Italy
 t. +39 0424 87633

PLANT 2
 Via L. Baden Powell, 11
 36045 Lonigo (VI)
 Italy
 t. +39 0444 720720

PLANT 3
 Via Vittoria, 158A
 36065 Mussolente (VI)
 Italy
 t. +39 0424 87506

PLANT 4
Onda USA L.L.C.
 600 London Rd
 Delaware, OH 43015
 t. +1 614 321 3342

Onda France S.A.R.L.
 320, Avenue Berthelot
 69008 Lyon France
 t. +33 472784606
 m. +33 608341000
 www.onda-fr.com
 onda@onda-fr.com

Onda USA L.L.C.
 600 London Rd
 Delaware, OH 43015
 t. +1 614 321 3342
 www.onda-us.com
 onda@onda-us.com

Onda RU
 Mayakovskogo Street, 18a, Khimki,
 Moscow Region, Russia 141402
 t. +7 495 971 88 53
 m. +7 916 676 16 54
 www.onda-it.com
 info@onda-ru.com

Onda Nordic OY
 Lentolantie 22
 36220 Kangasala Tampere, Finland
 t. +35 8331437300
 m. +35 8409012999
 www.wttgroup.fi
 pasi.makinen@wttgroup.fi

Onda Shanghai Heat Exchanger Co., Ltd.
 颐惠哒 (上海) 热交换有限公司
 Shanghai, Changning District,
 Anhua Road 492, Building 1 Tower A, Room 126
 上海市长宁区安化路492号1幢 (A座) 126室A092
 t. +86 021 6056 4838 (ext.1000)
 m. +33 6 08 34 10 00