



MAINTENANCE AND OPERATING MANUAL PLATE AND FRAME



ADVANCED HEAT EXCHANGERS

INDEX

	PAGE
Introduction	4
Use / warranty.....	4
Name plate	6
Safety instructions	7
Handling	8
Storage.....	9
Installation.....	9
Start-up.....	10
Operation.....	14
Interruption in operation for short periods	15
Maintenance.....	16
Replacement of plates and gaskets.....	20
Re-assembling of the PHE	20
Cleaning of the frame.....	21
Problem solving.....	21

★ ★ ★ ★ ★ ★ ★ ★ ★ ★

Operation and Maintenance Manual

Plate and Frame heat exchanger, Serie G

1. Introduction

First of all it is recommended to keep the present Manual always near the Plate heat exchanger.

It is moreover of the highest importance that the plate heat exchanger will be used exactly according to the thermal program calculated at the time of the purchase of the PHE. It is therefore important and recommended to keep a copy of the technical specification as well as the Declaration of Conformity together with this manual. Using the PHE at different conditions as those established on the technical specification, may be the cause of important differences in the performance or not function as it should.

The installation of the PHE as well as future maintenance operations should be carried out by qualified and instructed personnel only.

If the PHE needs special maintenance or structural changes, in that case please contact the manufacturer.

2. Use / Warranty

The Onda Plate & Frame PHE must be installed and used respecting the technical specification (thermal calculation), paying special attention to the following points:

- Avoid excessive temperatures which may damage the gaskets (install safety thermostats)
- Avoid "water hammers" which may both damage plates and gaskets. It is recommended to install a security valve.
- Do not use different fluids as those indicated in the technical specification, other fluids than those chosen in the design of the PHE may not be suitable for the chosen materials, i.e. plates and gaskets.
- Do not use the PHE at higher pressures than the maximum allowed pressure (PS) or the maximum allowed temperature (TS) as indicated in the technical specification and on the label attached to the PHE.
- The PHE must be used in accordance to the European Directive 97/23/CE (P.E.D.)

If changes to the PHE are required please contact ONDA for the necessary approval.

Important notice:

Onda warrants its equipment for the duration of 18 months as from the invoice date on the condition that the equipment has been used correctly according to the thermal program established in the documents part of the order. In case of a claim, the

customer must be able to show temperatures and pressure on both circuits. For this purpose a thermometer as well as pressure gauge should be installed.

Defects or inferior performances which are due to the non respect of the above recommendations will automatically cancel the warranty.

Warranty is not covered in case of normal wear, corrosion, fouling, or the use of incompatible fluids, responsible for damage to plates and gaskets.

Terms of the Onda Warranty:

A. ONDA S.p.A. warrants that the Products shall be free from defects in material and workmanship for a period of 18 months from the date of the delivery.

Therefore, should ONDA S.p.A., within the warranty period, acknowledge and recognise in writing the existence of the defects in the products and said defects be materially grounded, ONDA S.p.A. shall, at its discretion, repair the defective Products at no costs for the Client or replace them by delivering the substitutive products Ex works (Incoterms 2000) at ONDA S.p.A.'s premises.

ONDA's facilities located at via LORD Baden Powell, 11 – 36045 Lonigo (VI).

B. Subject to loss of the warranty, notice of any defect shall be given by the Client in writing with return receipt registered letter within, and not later than, 10 (ten) days from the date of receipt of the products at the Client's premises or in the different delivery place, previously indicated by the latter.

Subject to loss of the warranty, notice of any latent defect of the Products by the Client shall be given in writing, by return receipt registered letter, within and not later than 10 (ten) days from the date of the relevant discovery. It is hereby understood that the burden of the proof of the date of the discovery shall be borne by the Client.

C. ONDA S.p.A. also warrants that the Products are manufactured in compliance with the Italian and European Laws and Regulations in force on the date of the confirmation by ONDA S.p.A. of the relevant Client's order. Unless otherwise expressly agreed in writings by the parties, Client shall bear any other additional expenses related to the operations of repairing or replacing of the defective products.

D. This warranty shall not apply should the defects of the Products be caused by:

- natural wear and tear;
- unauthorised repairs or modifications;
- unsuited use or application;
- thermal overexposure, also when occasional;
- electrical or mechanical over-stress;

- failure of respecting the functional and environmental parameters suggested by ONDA S.p.A. for the correct use and exploitation of the products;
- installation of the products not in compliance with the technical specifications provided by ONDA S.p.A.;
- any other cause due to the Client's negligence or to occasional faults of the

products as consequence of mass-production procedures.

E. This warranty shall also not apply in case of:

- non-compliance of the Products with Laws and/or Regulations in force in the place where the Products are installed and/or assembled by the Client and/or in the place of their final use, should the Client not expressly require the conformity of the Products to said Laws and Regulations and not duly inform ONDA S.p.A. of their content before the date of transmission of the latter's order confirmation.
- This limitation of the warranty is also applicable with reference to peculiar Laws and Regulations valid and binding in States of the European Union independently of the European Laws and Regulations.

F. In the case of non-compliance of the Products with Italian and/or foreign Laws and/or Regulations entered in force after the date of transmission of the order confirmation by ONDA S.p.A., the replacement or any possible adjustment under warranty conditions will not be applied.

ONDA S.p.A. is, at any rate, not responsible for the use of the Products not conform to Italian and foreign Laws and/or Regulations entered in force after the date of transmission of their order confirmation by ONDA S.p.A.

G. The Client shall not sell or market Products not in compliance with the Laws and Regulations mentioned under letter E-F above. In the negative, the Client shall keep ONDA S.p.A. harmless of any damage or loss suffered by the latter, due to any third party's and/or authority's claim raised as a consequence of the manufacture by ONDA S.p.A. of Products not in compliance with the above mentioned Laws and Regulations.

H. Without prejudice to the application of DPR 224/1988 on product liability and liability for gross negligence or wilful misconduct, ONDA S.p.A. shall never be liable for direct, indirect or occasional damages which in any manner derived from defective products.

3. Identification label

Each PHE leaves our production plant with an identification label applied to the frame of the PHE.

On the label the max. allowed pressure is written, the minimum and maximum allowed temperatures, the PED classification, the kind of fluids (Group I or Group II) as well as the year of construction and serial number. These are the informations that are necessary in your communication with the manufacturer in case of requests of spare parts in order to easily trace and identify the unit.

 ONDA S.p.A.	
<small>Via Vittoria, 158/A - 36065 Mussolente (VI) Italy Tel.+39 0444 720720</small>	
MODEL	GT15 155 00-66-11 316L
CODE	RJ015N155AAA
SIDE	F1,F2 W1,W2
TIGHTENING MEASURE (mm)	48,1 mm
MIN/MAX ALLOWABLE TEMP (TS)	°100+ / °10-°C °100+ / °10-°C
MIN/MAX ALLOWABLE PRESSURE (PS)	10 bar 10 bar
TEST PRESSURE (PT)	16 bar 16 bar
VOLUME (V)	117,8 L 117,8 L
FLUID GROUP	WATER
BUILT	12-11-2019
SERIAL NUMBER	R1910634-002
<small>According to art.4, para.3 PED Directive 2014/68/EU</small>	

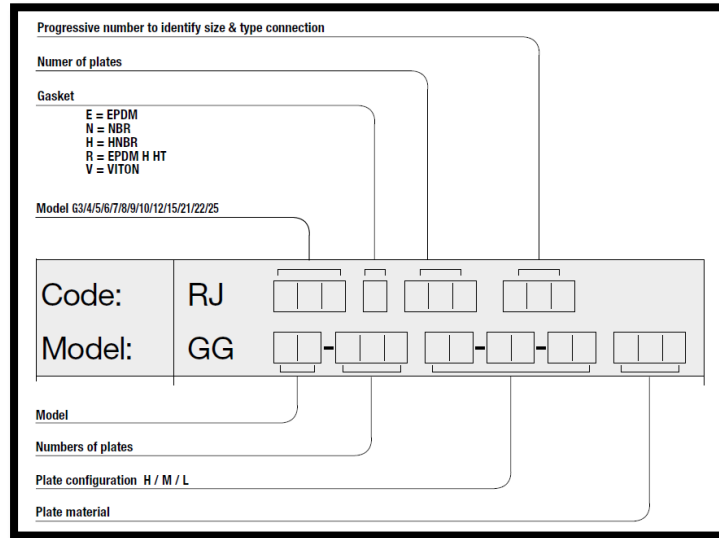

4. Safety instructions

Plate heat exchangers are equipment operating under pressure and must therefore be handled and maintained by adequately instructed and qualified personnel only. National and international regulations (EC 97/23/EG) must strictly be followed:

In case the PHE is operating with fluids of Group 1 or dangerous fluids or gases, it is necessary to apply special safety measures foreseen by the classification of dangerous fluids in Group I.

Before carrying out any kind of work /maintenance on the PHE please make sure that:

- Both circuits have been emptied
- The PHE is not under pressure
- The temperature is not above 40°
- The operator wears protective gloves

In case the PHE is operating with temperatures >90° the PHE should be equipped with a heat protection cover avoiding thus the risk of fluid projection in case of leakage. Single plates should be handled **always** wearing protective gloves since the plates have very sharp edges.

Components of the Plate heat exchanger

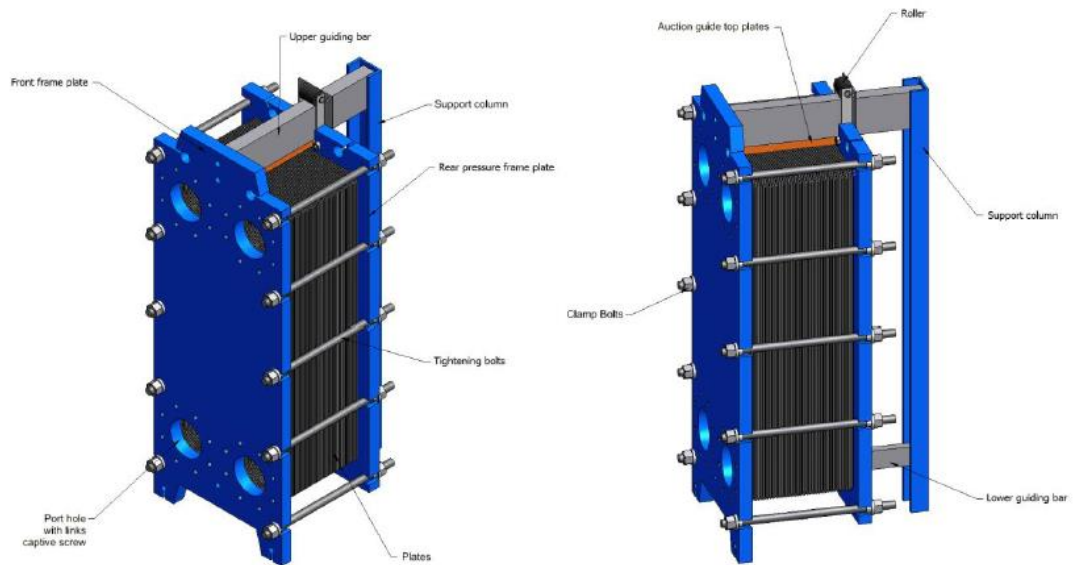

5. Handling

Small and medium sized PHE's are delivered usually fixed to a pallet, allowing handling and lifting by a forklift. PHE's of large dimensions and heavy weight must be handled using slings (in order not to damage the PHE never use metal chains) and be taken by the forks of the forklift or crane. Once the PHE is installed at its final destination it should be anchored to the ground or inside the plant, taking care to respect a minimum distance from walls or other machinery of 1,50/2.00 m. in order to facilitate handling of the PHE in case of maintenance.

N.B: Never lift the PHE at connections or flanges!

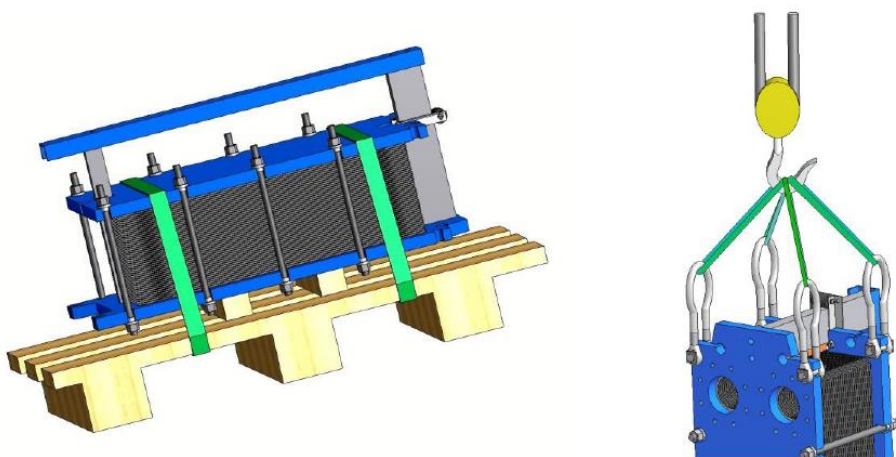



6. Storage

If the PHE will not be installed immediately after delivery, take care to store the PHE in a dry environment, protected from bad weather conditions at a temperature not $<5^{\circ}$ and not $>$ to 60° . If the PHE is stored outdoors, avoid direct sunlight and protect the PHE with an adequate cover isolating it from umidity and freezing. Under these conditions foresee the greasing of the tightening bolts and studs against rusting.

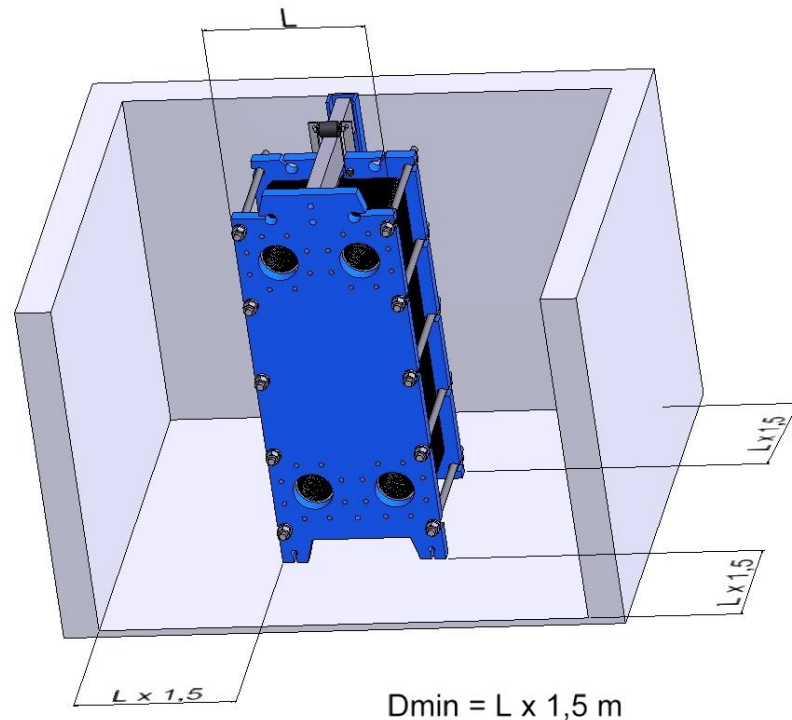

7. Installation

- Install vent valves at the highest points of the connections, allowing the air to leave the PHE during the filling of the unit;
- In case of multipass PHE's avoid the obstruction with fixed piping of the opening space between the mobile (rear) frame plate and rear support enabling an easy opening of the PHE during maintenance;
- Check the correct tightening measure of the plate pack ($n_p \times \dots \text{mm}$)
- In order to avoid water hammers or sudden pressure variations install shock absorbers between the feeding pipes and PHE; Do not install quick-closing- and opening valves.
- Install closing and opening valves on the pipes enabling the isolation of the PHE during maintenance.

The PHE is designed for normal indoor installation at room temperature. If an outdoor installation is required where it could be subject to extreme climatic conditions, is it necessary to provide the PHE with an adequate isolation. Isolation must be ordered together with the PHE.

The PHE must be installed on perfectly a flat ground in a vertical position

8. Start-up of the PHE

Primary circuit:

- a. Feed valve between pump and PHE remains closed
- b. Open the outlet valve (if installed) on the connection completely
- c. Open the vent
- d. Start the pump
- e. Make sure the feed valve is opened slowly
- f. Make sure the air has completely escaped the PHE and close the vents.

Secondary circuit:

Repeat the same procedure as above.

START-UP

During start-up, check that no visible leakages appear from the plate pack, valves or piping system.

1 Before start-up check that all tightening bolts are firmly tightened and that the dimension A is correct. Refer to PHE dimensioning sheet.

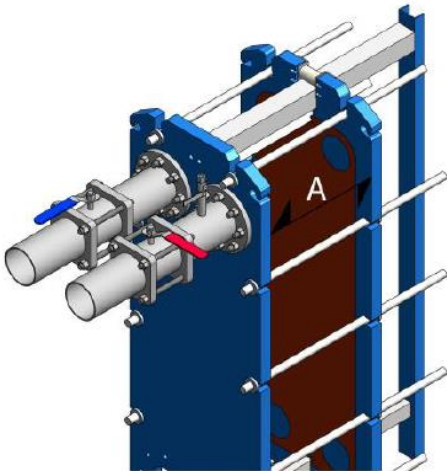

2 Check that the valve is closed between the pump and the unit controlling the system flow rate.

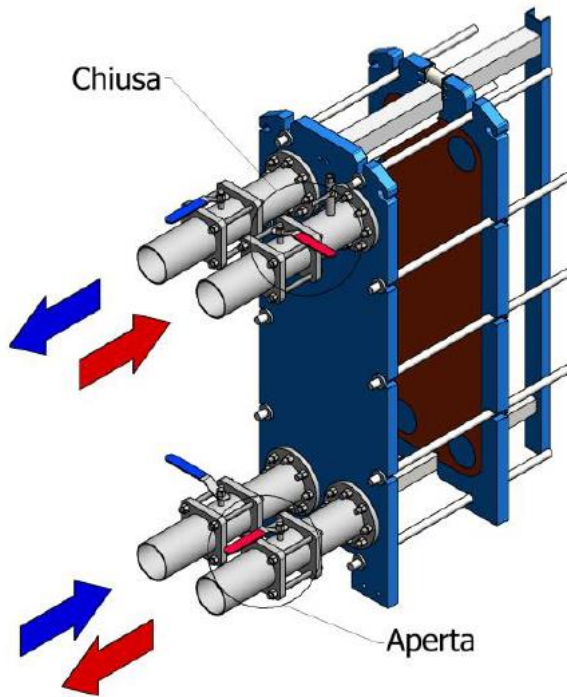

3 If there is a valve at the exit, make sure it is fully open.

4 Open the air vent and start the pump.

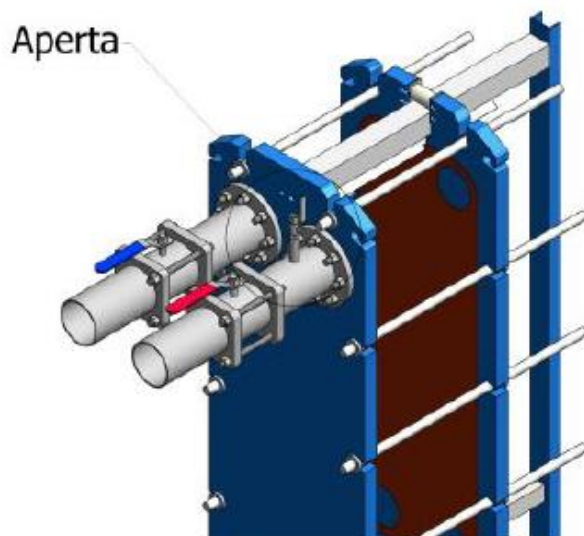

5 Open the valve slowly.

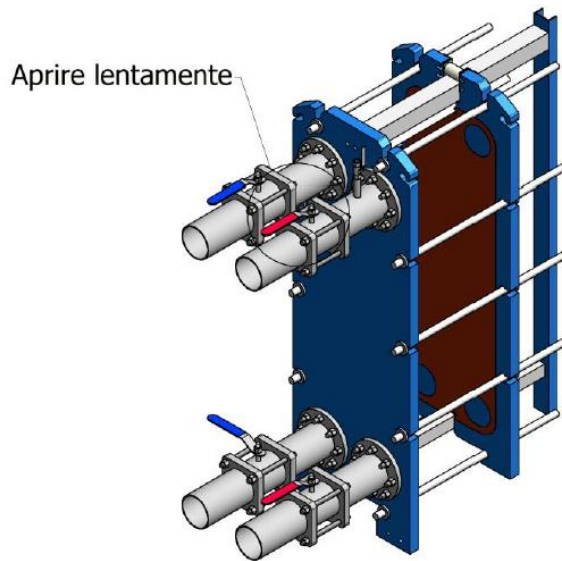

6 When all air is expelled, close the air vent.

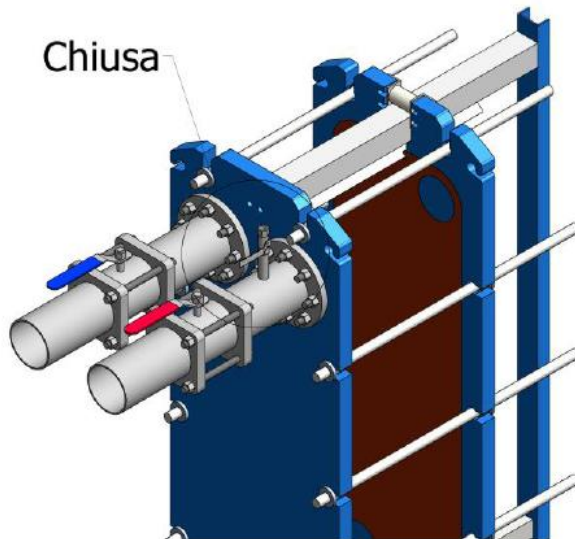

7 Repeat steps 1-6 for the second media.

Pressure test

If during a test it is noticed that there is a pressure variation between the two circuits it is just matter to wait 2-3 min and the pressure will stabilize.

The reason is due to plates internal movements which create small channels volume variation.

Guidelines for the pressure test

	PN-10		PN-16	
	F1-F2 [barg]	W1-W2 [barg]	F1-F2 [barg]	W1-W2 [barg]
STEP-1	4		4	
STEP-2		4		4
STEP-3		16		21
STEP-4	16		21	
STEP-5	Wait 2 -3 min for pressure stabilization			
STEP-6	Circuits pressure adjustment (if needed)			
STEP-7	Circuits pressure recording			

SHUT-DOWN

- 1 Slowly close the valve controlling the flow rate of the pump you are about to stop.

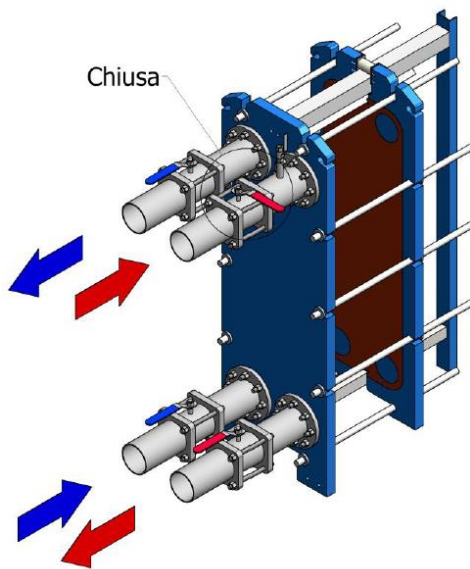

- 2 When the valve is closed, stop the pump.
- 3 Repeat steps 1-2 for the other side for the second media.
- 4 If the PHE is shut down for several days or longer, it should be drained. Draining should also be done if the process is shut down and the room temperature is below the freezing temperature of the media. Depending on the media processed, it is also recommended to rinse and dry the PHE plates and connections.

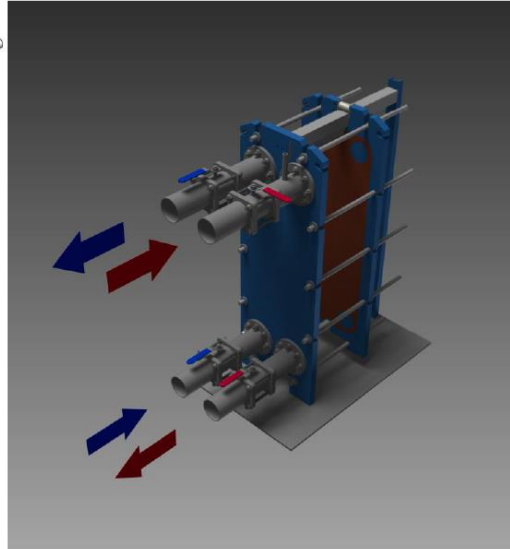
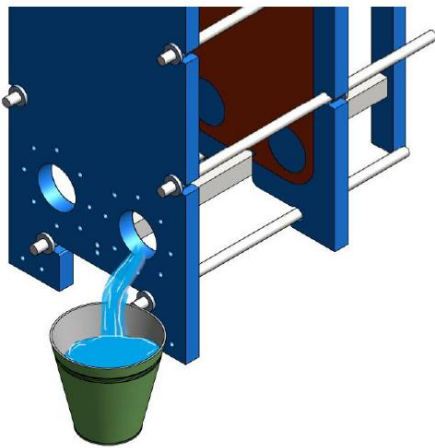

9. Operation

During operation the design pressure and design temperature, indicated on the label and the technical specification of the PHE must be respected and in no case be exceeded.

It is mandatory to avoid sudden temperature exceeding as well as water hammers.

These circumstances may severely damage the PHE's components and will automatically cancel the validity of the warranty, and Onda may not be held liable for any damages or consequential damage.

In case a temperature exceeding or waterhammer occurs, the PHE must be put out of operation in order to eliminate the cause of the defect. Under normal operating circumstances it is recommended to check the perfect functioning of the PHE in the plant at least once a year and to check the functional parameters such as pressure, temperatures and pressure drop on a monthly basis. Variations in these parameters may be the sign of fouling inside the PHE.

Circuito a passaggio singolo

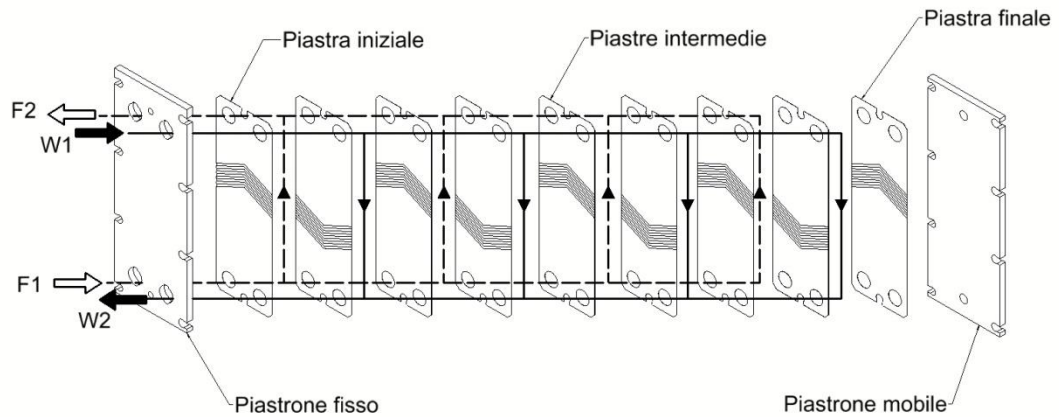

Circuito a doppio passaggio

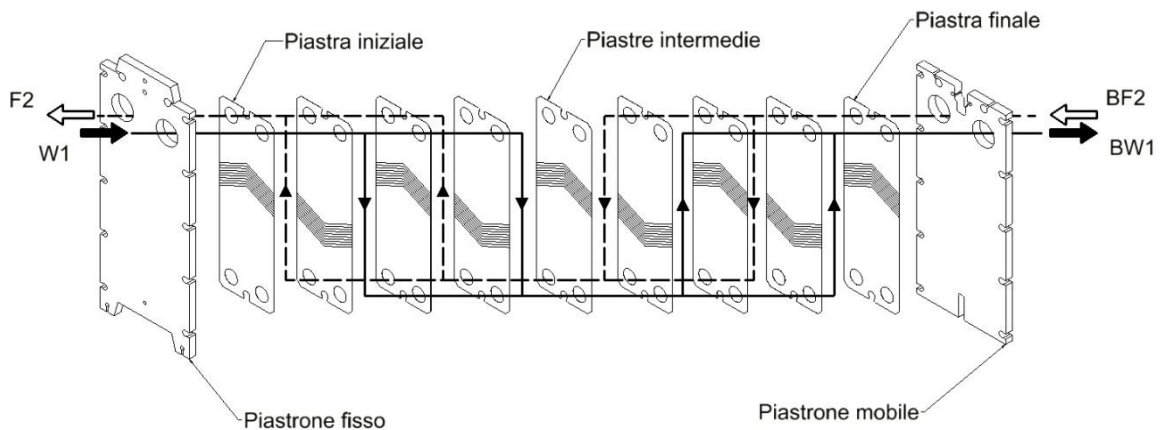

10. Interruption in operation for short periods:

- 1) Gradually close the feeding valves with priority to the circuit with the highest pressure;
- 2) Switch of the pumps
- 3) Close the valves on the outlet pipes

For longer interruptions add the following procedure to the points above:

1. Let the PHE cool-off until room temperature
2. Completely drain both circuits and vent the heatexchanger
3. Rinse the plate package with water and eliminate eventual dirt

4. Unscrew the nuts of the tightening bars in order to loosen the plate package increasing the tightening dimension by 10% approx
5. For longer periods tightening bars and nuts should be treated with a rust resisting grease.

11. Maintenance

Normal maintenance frequency depends on the application and kind of fluids entering the PHE.

We recommend to do one yearly maintenance during which the PHE should be completely opened and checked according to pt. 9.

Moreover is it important to check the gaskets which may have lost some of their spring back: This might require small adjustments in the tightening measure of the plate pack, which may be tightened until the minimum allowed value. Please check the label on the PHE where min and max tightening dimensions are mentioned.

Before opening the PHE the following operations are recommended:

- Clean the plate pack externally, the roller of the guiding bar, upper and under guiding bar and lubricate the roller;

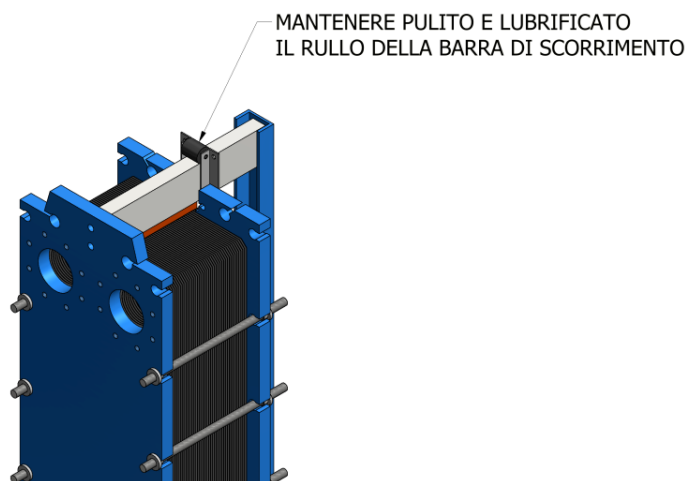

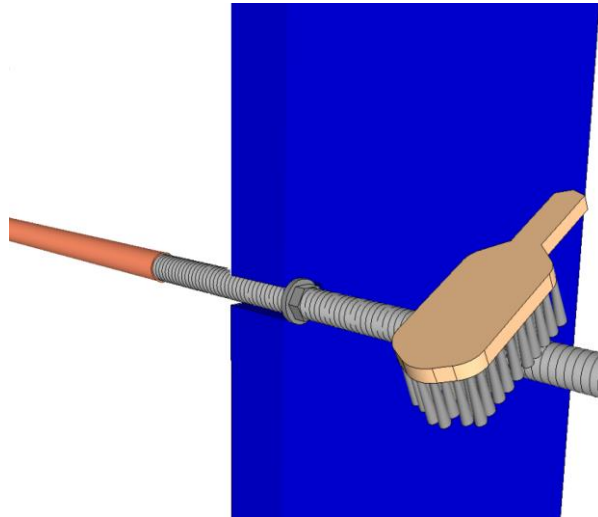
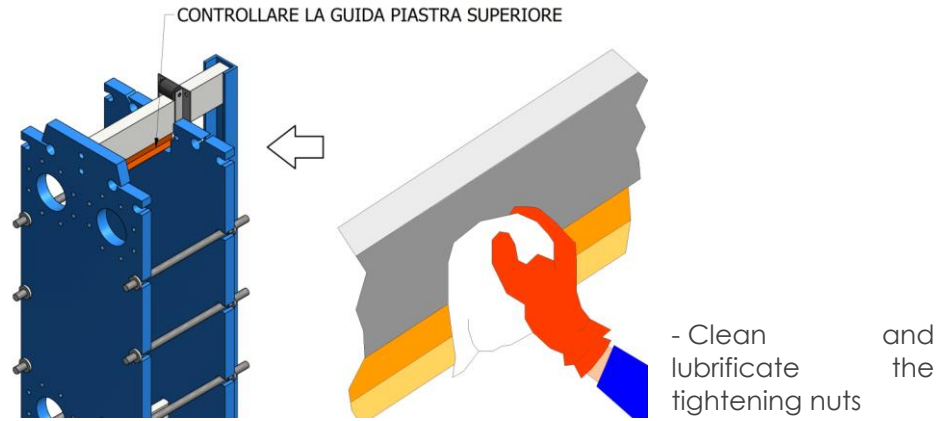

- Colour a diagonal line across the side of the plate pack, this will help the operator to reassemble the plate pack easily after maintenance. Before opening take care to write down the tightening dimension value before the opening of the PHE.

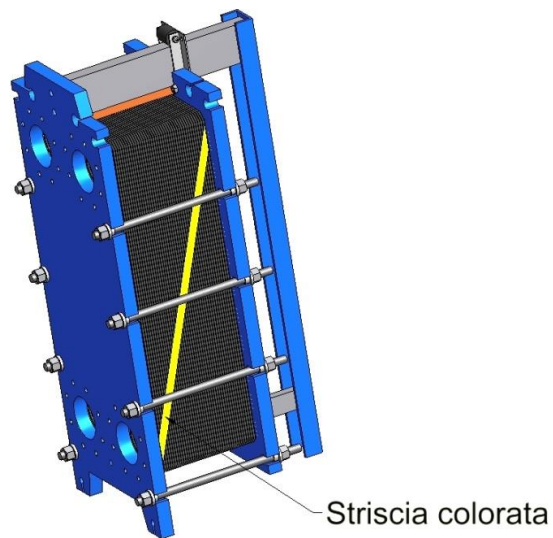

Dissassembling of the tightening nuts and opening of the PHE:

Tightening measure of the plate package

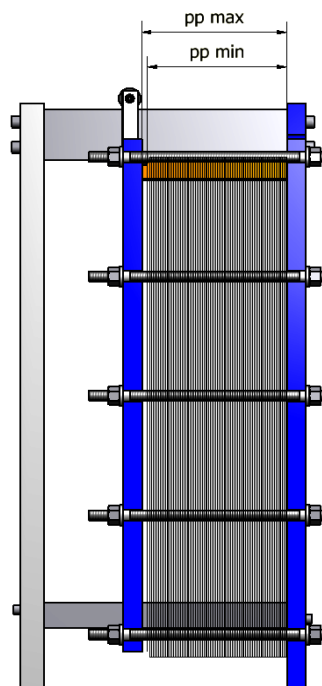

The nuts nr. 5-6-7-8-9 may be removed without a special order, while nuts nr. 1- 2- 3- 4 will be unscrewed afterwards, diagonally 1-2 / 3-4, repeating the same operation until the plate pack is completely free of pressure. At the end of this operation the rear frame plate may be moved towards the rear support, leaving the plate pack completely free.

To remove the plate from the guiding bar, move the lower part of the plate towards the rear frame plate, removing it from the lower guiding bar, turn it towards the outside and

take the plate away from the pack. During all operations with the plates the operator should always wear protective gloves while the edges are very sharp.

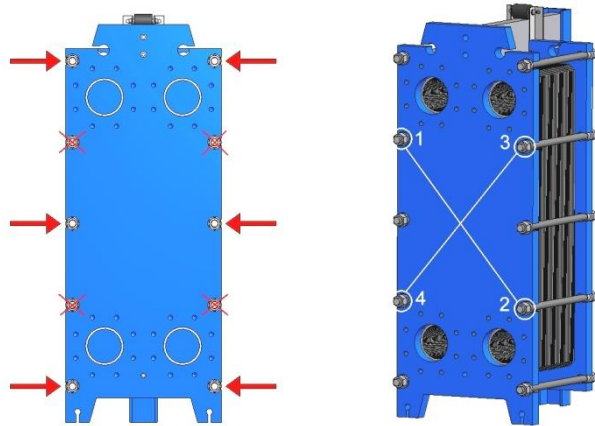

Cleaning of the plates:

If the plate pack is not too dirty, the plates may be cleaned while the pack is open and using a soft brush and warm water. If the plates have f.e. incrustations a high pressure cleaner may be used, taking care not to use metallic brushes or abrasive products.

Take care to avoid the gaskets with the high pressure water jet so that the gaskets will not be damaged and remain in place in their seat. Especially resisting deposits may be removed in a chemical bath.

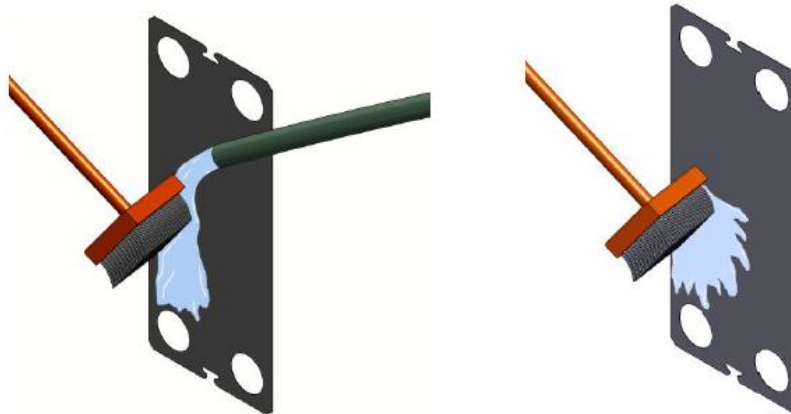

Recommended detergents: (check that detergents are suitable for plate and gasket materials)

- Calcar/calcium and incrustations: Phosphoric acid at max. 20°, concentration max. 5% for approx. 1 hour

- Oils, greases: Caustic soda solution at 85° , concentration max. 4%
For approx 24 hrs.

- Mud and metal oxides: Nitric acid at 60°, concentration max. 8% or citric acid, concentration of 4% at max. 60°.

Important:

Do not use hydrochloric acid (HLC) or water with chloride to clean stainless steel plates;

Do not use phosphoric acid on titanium plates

N.B. Always check and keep strictly to the safety instructions from the detergent manufacturer.

12. Replacement of plates and gaskets

The gaskets are fixed easily into their seat, without the need of glues inside the groove. Before fixing the new gasket to the plate, accurately clean the groove.

13. Re-assembling of the PHE

- Check that both plate and gaskets are perfectly clean. The smallest impurity may be the cause of a leakage.
- Lubricate the upper guiding bar.
- Re-arrange the plates back into the PHE frame according to the assembly scheme, in reverse order. Pay attention to the first and final plate which are in direct contact to the front and rear frame plate. The gasket of the first plate must be placed against the rear (fixed) frame plate. Check the correct plate pack assembly by observing the coloured diagonal line applied before the disassembling. Moreover if the plate pack is correctly assembled the external side of the plate pack form a regular honeycomb design. Small plate heat exchangers may be re-assembled in a horizontal position lying on the rear (fixed) plate.

Correct assembling of the plate package

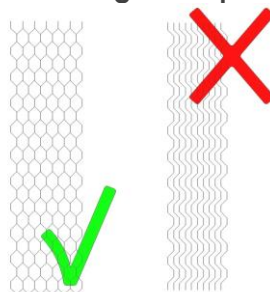

- Slowly return the front plate back to the plate pack.
- Introduce the tightening bolts 1 – 2 – 3 – 4 from the side and fix the counter nuts tightly to the rear (fixed) plate.

- Fasten the tightening bolts 1-4 uniformly and in rotation (alternating and diagonal 1-2 and 3-4). During tightening always check the tightening dimension. During the tightening the angle should not exceed 10 mm over the width and 20 mm over the diagonal.
- Tighten the plate package to the same tightening measure from before the opening of the PHE. Tighten the remaining bolts to the same tightening measure as bolts 1-2-3-4.

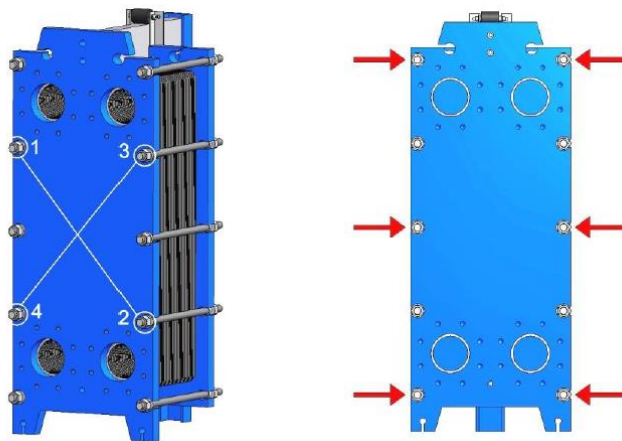

Important notice:

If the PHE is leaking during the pressure test, the plate pack may be tightened slowly taking care not to exceed with more than some mm the tightening measure of before the opening and indicated on the PHE label. Exceeding further may seriously damage both plates and gaskets which may cause other leakages. If the leakages proceed, contact the manufacturer.

In order to allow easy maintenance and opening of the PHE take care to regularly lubricate all moving parts of the PHE (nuts, washers, bolts, roller and guiding bars).

14. Cleaning of the frame:

The frame in painted carbon steel may be cleaned with a sponge, cloth or brush, using a slightly alkaline solution. In case the painting of the frame is damaged it is recommended to repair the painting as soon as possible.

15. Problem solving

Fluid leakage between connections and fixed plate (leakage from connections at frame plate):

May be due to:

- Mechanical stresses on the connections
- Faulty ring gasket, connection or flange
- Material fatigue or wear



Solutions:

- Check correct tightening of the bolts
- Check eventual mechanical stresses from the piping system on the gasket
- Check the correct alignment of the piping and flanges and eventually correct if necessary

Fluid leakage between plate package and fix/mobile frame plate (leakage from the bottom)

May be due to:

- Faulty gasket between plate and inside area of the frame plate
- Faulty gasket or fault in the groove of the first gasket
- Material fatigue or wear

Solutions:

- Identify and sign with a marker place of leakage
- Open the PHE following the procedure at pt. 11
- Check whether the first gasket is correctly seated in its groove and touching the frame plate;

External Leakage from the platepackage

May be due to:

- Exceeding of the allowed temperature/pressure
- The mobile frame plate is not tightened plane-parallel
- Wrong tightening measure
- Faulty or damaged gaskets
- Wear of the gaskets

Solutions:

- Correct pressure and temperature to design values
- If necessary, tighten the frame plate until perfect plane-parallel position. If necessary correct tightening dimensions (increasing or diminishing) very carefully taking care not to exceed the tightening dimensions more than some millimeters. The difference between the tightening measure between single bolts should not exceed more than 2 mm.
- If after the above solutions no result is obtained, open the PHE and check the correct positioning of all gaskets in the groove, replace eventual damaged gaskets.

Internal leakage / mixture of the fluids

May be due to:

- Corrosion on the plate
- Crack in the plate

Solutions:

- Open the PHE
- Empty one of both circuits
- Disconnect the tubes to the emptied circuit
- Give a slight pressure to the second and still connected circuit
- The fluid escapes through the leakage to the open circuit and then leaves the PHE through the connections.
- Using a strong light it is possible to locate the faulty plate
- Check the complete plate and its gasket, clean them and if necessary replace them
- both.

In case of a very small crack on the plate which is invisible to the eye, each plate and gasket of the plate pack should be checked, replacing the eventual faulty plate,s if any, and its gasket. In case no fault is found a complete crack test will be required in order to find the faulty plates. In that case please contact the manufacturer.

The performance is seriously diminishing

If the pressure drop is increasing, or the performance decreases seriously, first check if the cause is due to the production plant, externally of the PHE, f.e. change in the fluids, the temperatures or the flow rates). If the PHE does not improve its performance stopping the PHE, opening and cleaning is necessary.

Max. tightening measure has been reached

If the gaskets, due to fatigue or wear have completely lost their flexibility and have been compressed at the maximum limit, the gaskets will not be able to guarantee the perfect leak-tightness. All gaskets must be replaced.



ONDA

Advanced
Heat Transfer
Solutions



ADVANCED HEAT EXCHANGERS

ONDA S.p.A.

onda@onda-it.com
www.onda-it.com

PLANT 1 Headquarters

Via Dante Alighieri, 27B
36065 Mussolente (VI)
Italy
t. +39 0424 87633
f. +39 0424 578667

PLANT 2

Via L. Baden Powell, 11
36045 Lonigo (VI)
Italy
t. +39 0444 720720
f. +39 0444 720721

PLANT 3

Via Vittoria, 158A
36065 Mussolente (VI)
Italy
t. +39 0424 87506
f. +39 0424 87744