

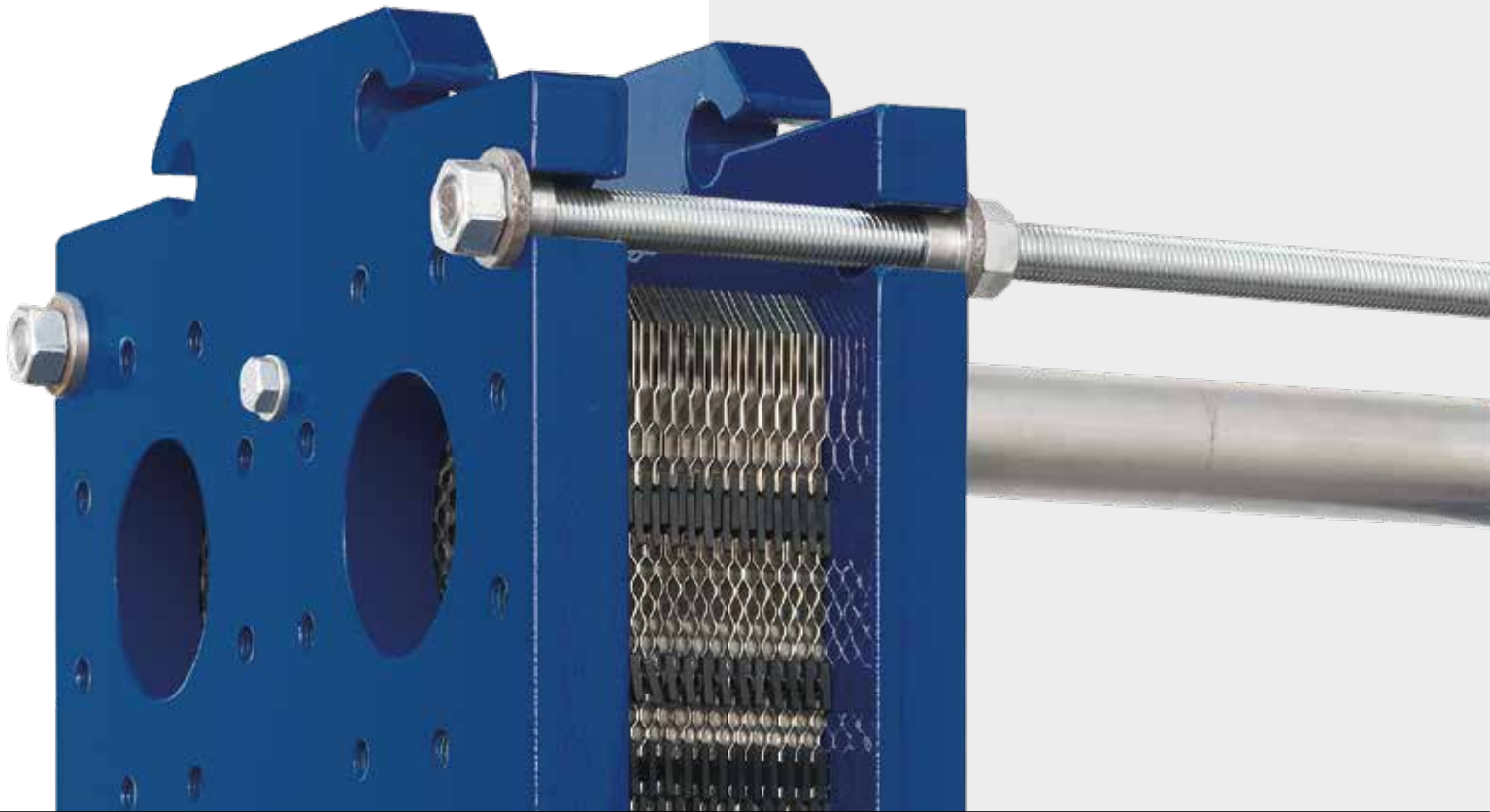

ADVANCED HEAT EXCHANGERS

PLATE & FRAME



Scambiatori di calore a piastre ispezionabili

Onda, specialista di diverse tipologie di scambiatori di calore di qualità, propone una gamma di scambiatori di calore ispezionabili. Disponibile in diversi modelli e dimensioni, gli scambiatori di calore ispezionabili Onda offrono soluzioni a quesiti di scambio termico in una varietà innumerevole di applicazioni in tutti i settori civili (HVAC) ed industriali (di processo, navale, chimico, petrolchimico) nonché la cogenerazione ed il teleriscaldamento/raffreddamento.

Descrizione:

Le piastre sono disponibili con due diversi corrugazioni, sia in H (alta resa) sia in L (bassa resa), permettendo, attraverso la combinazione delle due corrugazioni, la perfetta ottimizzazione delle perdite di carico. Le guarnizioni sono state progettate con il sistema Easyfix al fine di facilitare il fissaggio degli stessi alle piastre garantendo una perfetta tenuta.

Certificazioni:

ISO 9001 Vision 2000
P.E.D. (European pressure Directive 97/23 CE)
ASME (su richiesta)

Materiali:

Telaio: Acciaio al carbonio verniciato
Piastre: AISI 316L / TITANIO / AISI 304L
Guarnizioni: NBR (100°C max) / EPDM (120°C max) / HNBR EPDM H HT
Conessioni: AISI 316 / PVC

Optional:

Coibentazioni disponibili su richiesta
Involucro in lamiera stampata in acciaio inox Aisi 304 o alluminio
Materiale isolante Armaflex spessore 16mm
Staffe di fissaggio

Gasketed Plate heat exchangers

As a specialist of various kinds of heat exchangers, Onda offers a range of gasketed plate heat exchangers.

The gasketed Plate heat exchangers are available in various models and dimensions and always offer the best solution to a great variety of heat exchange applications coming from both the HVAC and the industry such as the powerindustry, marine, chemical, heavy industry etc., as well as cogeneration and district heating-and cooling applications.

Description:

The plates are available in two different designs, both in H (high efficiency) and L (low efficiency), enabling pressure drop optimization through the combination of both plates. The gaskets have been designed with the Easyfix system in order to enable an easy fastening of the gaskets to the plates and guarantee perfect leak-tightness.

Certifications:

ISO 9001 Vision 2000
P.E.D. (European pressure Directive 97/23 CE)
ASME (on request)

Materials:

Frame: Carbon steel, painted
Plates: AISI 316L / TITANIUM / AISI 304L
Gaskets: NBR (100°C max) / EPDM (120°C max) / HNBR HPDM H HT
Tightening bolts: galvanized steel
Connections: AISI 304 / AISI 316 / PVC / POM-C

Optional:

Insulations available on request
Casing in formed Stainless Steel AISI 304 or Aluminium
Internal insulating material Armaflex thickness 16mm
Mounting feet



Via Vittoria, 158/A - 36065 Mussolente (VI) Italy Tel.+39 0444 720720

MODEL	GT15 155 00-66-11 316L		
CODE	RJ015N155AAA		
SIDE	F1,F2	W1,W2	
TIGHTENING MEASURE (mm)	48,1 mm		
MINMAX ALLOWABLE TEMP. (TS)	-10°C / +100°C	-10°C / +100°C	
MAX ALLOWABLE PRESSURE (PS)	10 bar	10 bar	
TEST PRESSURE (PT)	16 bar	16 bar	
VOLUME (V)	117,8 L	117,8 L	
FLUID GROUP	WATER		
BUILT	12-11-2019		
SERIAL NUMBER	R1910634-002		
According to art.4, para.3 PED Directive 2014/68/UE			

Progressive number to identify size & type connection

Numer of plates

Gasket

- E = EPDM
- N = NBR
- H = HNBR
- R = EPDM H HT
- V = VITON

Model G3/4/5/6/7/8/9/10/12/15/21/22/25

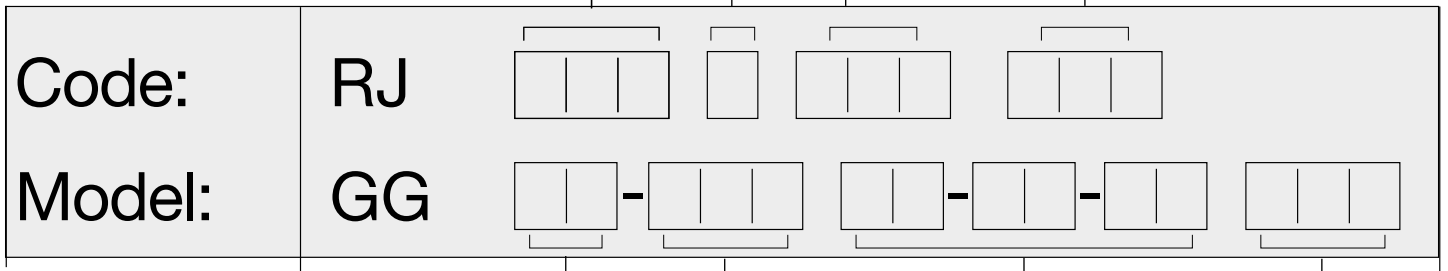

Model

Numbers of plates

Plate configuration H / M / L

Plate material

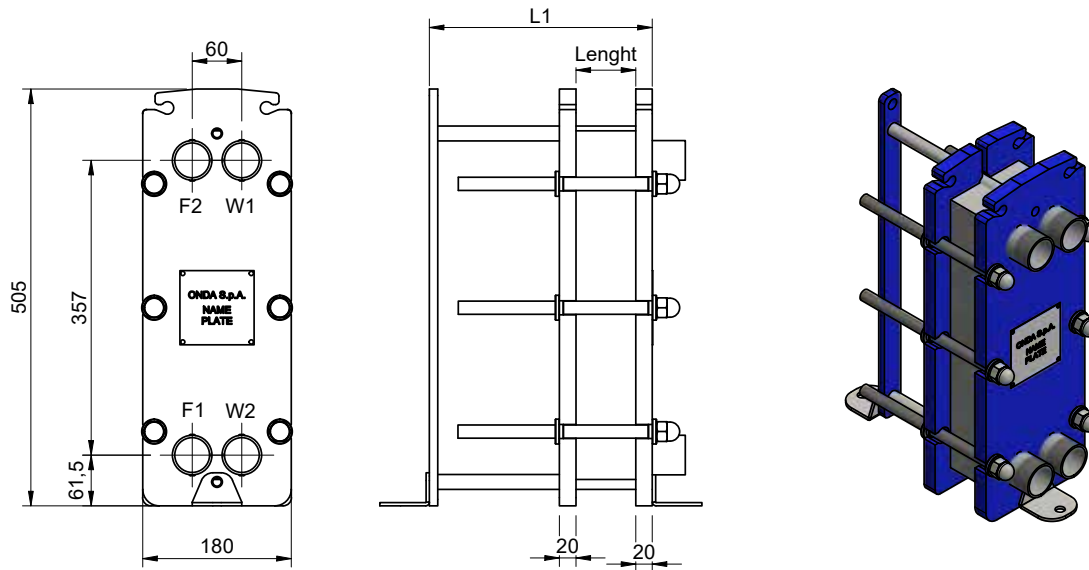

L1

N° plate	0-25	26-50	51-75	76-100	101-150	151-200	201-250
GG003 (2,90)	250	330	500	500	NO	NO	NO

SPECIFICATIONS	GG003 PN10	GG003 PN16
PRESSURE RANGE (bar)	10	16
TEMPERATURE RANGE (°C) NBR	-10°C to +100°C	-10°C to +100°C
TEMPERATURE RANGE (°C) EPDM	-10°C to +120°C	-10°C to +120°C
MAXIMUM CONNECTIONS AVAILABLE (mm)	Ø 34mm	Ø 34mm
MAXIMUM FLOW RATE (m³/h)	18	18
VOLUME / CHANNEL (liters)	0,08	0,08
DIMENSIONS (mm)	180x480	180x480
LENGHT CALCULATION (mm)	N x 2,9	N x 2,9
WEIGHT CALCULATION (kg)	N x 0,2 + 31	N x 0,2 + 31

CONNECTIONS TYPE

DN32	
1" 1/4 GAS	1" 1/4 NPT

- F1 INLET CIRCUIT 1
- F2 OUTLET CIRCUIT 1
- W1 INLET Secondary Fluid
- W2 OUTLET Secondary Fluid

Plate material	AISI 304L / AISI 316L / TITANIUM
Plate thickness	0,5mm
Gasket material	NBR / EPDM / VITON / HNBR / EPDM H HT
Frame material	P265GH CARBON STEEL
Frame colour	RAL 5002 SEMIGLOSS FINISHING
Tie rod	N° 6 M16 GALVANIZED CLASS 8.8
Pressure	PN 10 - PN16
Material connections	AISI 304 / AISI 316 / POM-C

GG004

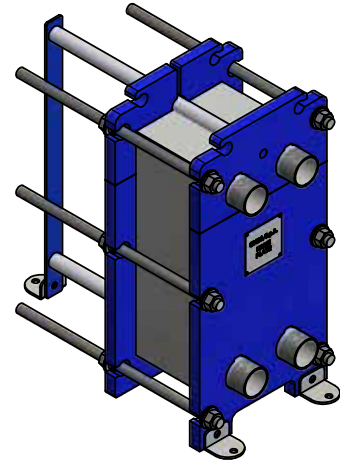
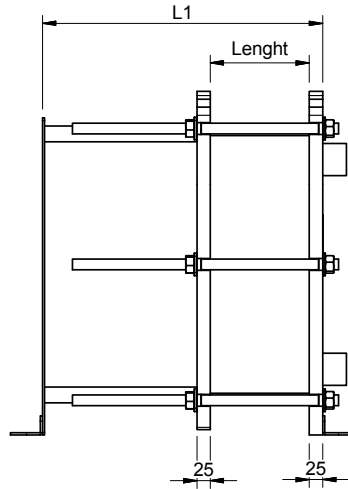
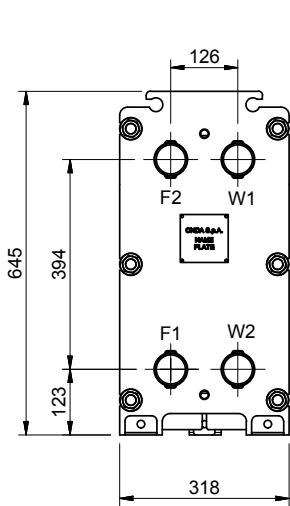

L1							
N° plate	0-25	26-50	51-75	76-100	101-150	151-200	201-250
GG004 (3,0)	250	330	500	750	750	NO	NO

SPECIFICATIONS	GG004 PN10	GG004 PN16
PRESSURE RANGE (bar)	10	16
TEMPERATURE RANGE (°C) NBR	-10°C to +100°C	-10°C to +100°C
TEMPERATURE RANGE (°C) EPDM	-10°C to +120°C	-10°C to +120°C
MAXIMUM CONNECTIONS AVAILABLE (mm)	Ø 58mm	Ø 58mm
MAXIMUM FLOW RATE (m³/h)	52	52
VOLUME / CHANNEL (liters)	0,13	0,13
DIMENSIONS (mm)	318x645	318x645
LENGHT CALCULATION (mm)	N x 3	N x 3
WEIGHT CALCULATION (kg)	N x 0,47 + 90	N x 0,47 + 90

CONNECTIONS TYPE	
DN50	
2" GAS	2" NPT

F1 INLET CIRCUIT 1
 F2 OUTLET CIRCUIT 1
 W1 INLET Secondary Fluid
 W2 OUTLET Secondary Fluid

Plate material AISI 304L / AISI 316L / TITANIUM
 Plate thickness 0,5mm
 Gasket material NBR / EPDM / VITON / HNBR / EPDM H HT
 Frame material P265GH CARBON STEEL
 Frame colour RAL 5002 SEMIGLOSS FINISHING
 Tie rod N° 6 M20 GALVANIZED CLASS 8.8
 Pressure PN 10 - PN16
 Material connections AISI 304 / AISI 316 / POM-C

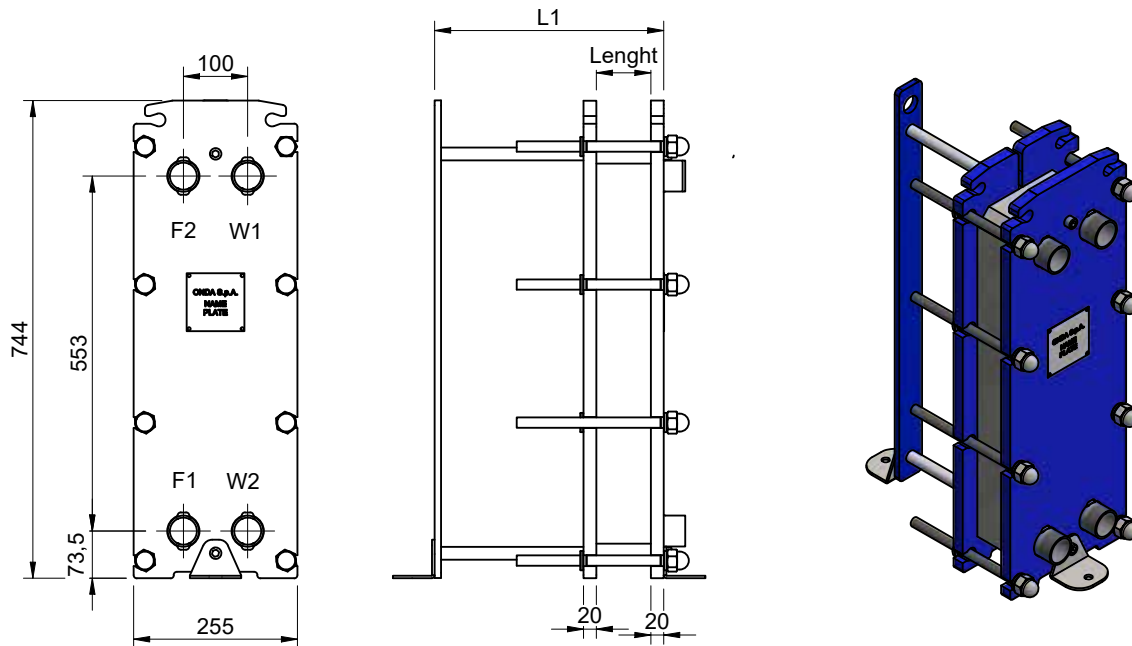

L1

N° plate	0-25	26-50	51-75	76-100	101-150	151-200	201-250
GG005 (3,4)	250	330	500	500	NO	NO	NO

SPECIFICATIONS	GG005 PN10	GG005 PN16
PRESSURE RANGE (bar)	10	16
TEMPERATURE RANGE (°C) NBR	-10°C to +100°C	-10°C to +100°C
TEMPERATURE RANGE (°C) EPDM	-10°C to +120°C	-10°C to +120°C
MAXIMUM CONNECTIONS AVAILABLE (mm)	Ø 40mm	Ø 40mm
MAXIMUM FLOW RATE (m³/h)	24	24
VOLUME / CHANNEL (liters)	0,24	0,24
DIMENSIONS (mm)	255x700	255x700
LENGHT CALCULATION (mm)	N x 3,4	N x 3,4
WEIGHT CALCULATION (kg)	N x 0,5 + 62	N x 0,5 + 62

CONNECTIONS TYPE

DN40	
1" 1/2 GAS	1" 1/2 NPT

- F1 INLET CIRCUIT 1
- F2 OUTLET CIRCUIT 1
- W1 INLET Secondary Fluid
- W2 OUTLET Secondary Fluid

Plate material	AISI 304L / AISI 316L / TITANIUM
Spessore plate	0,5mm
Gasket material	NBR / EPDM / VITON / HNBR / EPDM H HT
Frame material	P265GH CARBON STEEL
Frame colour	RAL 5002 SEMIGLOSS FINISHING
Tie rod	N° 8 M16 GALVANIZED CLASS 8.8
Pressure	PN 10 - PN16
Material connections	AISI 304 / AISI 316 / POM-C

GG006

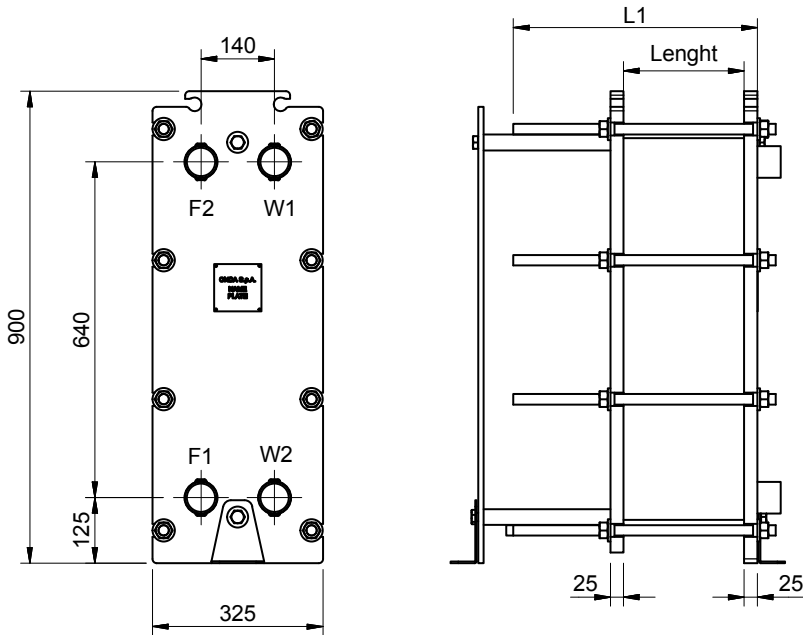

L1							
N° plate	0-25	26-50	51-75	76-100	101-150	151-200	201-250
GG006 (3,5)	250	330	500	750	1000	NO	NO

SPECIFICATIONS	GG006 PN10	GG006 PN16
PRESSURE RANGE (bar)	10	16
TEMPERATURE RANGE (°C) NBR	-10°C to +100°C	-10°C to +100°C
TEMPERATURE RANGE (°C) EPDM	-10°C to +120°C	-10°C to +120°C
MAXIMUM CONNECTIONS AVAILABLE (mm)	Ø 58mm	Ø 58mm
MAXIMUM FLOW RATE (m³/h)	52	52
VOLUME / CHANNEL (liters)	0,42	0,42
DIMENSIONS (mm)	325x900	325x900
LENGHT CALCULATION (mm)	N x 3,5	N x 3,5
WEIGHT CALCULATION (kg)	N x 0,7 + 125	N x 0,7 + 125

CONNECTIONS TYPE	
DN50	
2" GAS	2" NPT

F1 INLET CIRCUIT 1
 F2 OUTLET CIRCUIT 1
 W1 INLET Secondary Fluid
 W2 OUTLET Secondary Fluid

Plate material AISI 304L / AISI 316L / TITANIUM
 Plate thickness 0,5mm
 Gasket material NBR / EPDM / VITON / HNBR / EPDM H HT
 Frame material P265GH CARBON STEEL
 Frame colour RAL 5002 SEMIGLOSS FINISHING
 Tie rod N° 8 M20 GALVANIZED CLASS 8.8
 Pressure PN 10 - PN16
 Material connections AISI 304 / AISI 316 / POM-C

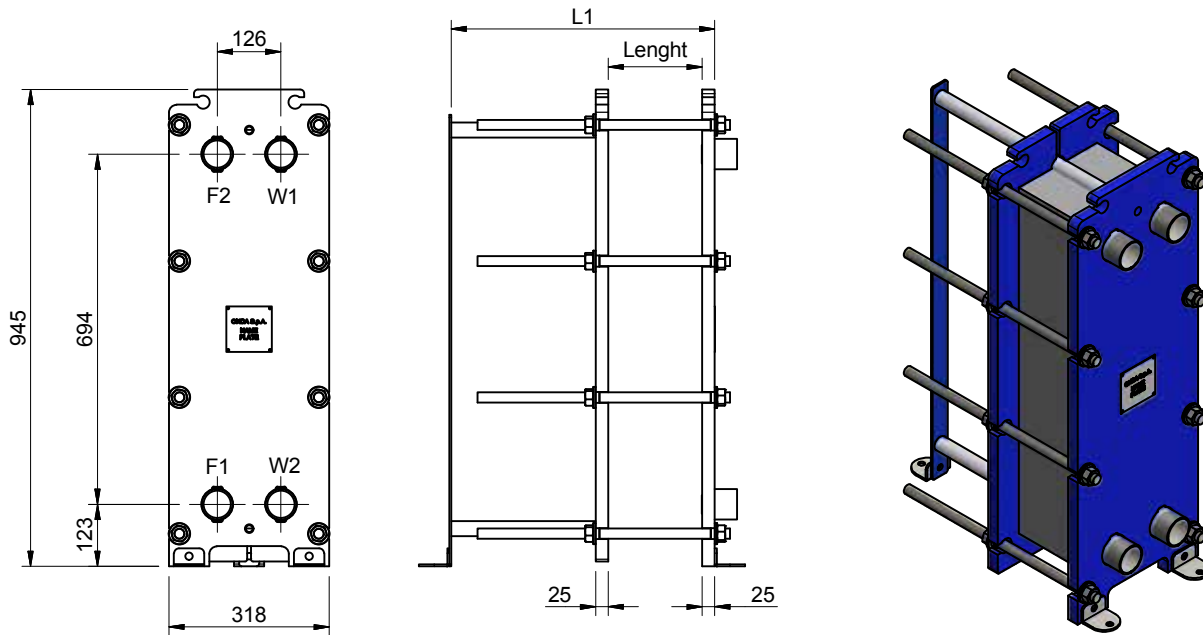

L1							
N° plate	0-25	26-50	51-75	76-100	101-150	151-200	201-250
GG007 (3,0)	250	330	500	750	750	NO	NO

SPECIFICATIONS	GG007 PN10	GG007 PN16
PRESSURE RANGE (bar)	10	16
TEMPERATURE RANGE (°C) NBR	-10°C to +100°C	-10°C to +100°C
TEMPERATURE RANGE (°C) EPDM	-10°C to +120°C	-10°C to +120°C
MAXIMUM CONNECTIONS AVAILABLE (mm)	Ø 58mm	Ø 58mm
MAXIMUM FLOW RATE (m³/h)	52	52
VOLUME / CHANNEL (liters)	0,42	0,42
DIMENSIONS (mm)	318x945	318x945
LENGHT CALCULATION (mm)	N x 3	N x 3
WEIGHT CALCULATION (kg)	N x 0,75 + 132	N x 0,75 + 132

CONNECTIONS TYPE	
DN50	
2" GAS	2" NPT

F1 INLET CIRCUIT 1
F2 OUTLET CIRCUIT 1
W1 INLET Secondary Fluid
W2 OUTLET Secondary Fluid

Plate material AISI 304L / AISI 316L / TITANIUM
 Plate thickness 0,5mm
 Gasket material NBR / EPDM / VITON / HNBR / EPDM H HT
 Frame material P265GH CARBON STEEL
 Frame colour RAL 5002 SEMIGLOSS FINISHING
 Tie rod N° 8 M20 GALVANIZED CLASS 8.8
 Pressure PN 10 - PN16
 Material connections AISI 304 / AISI 316 / POM-C

GG008

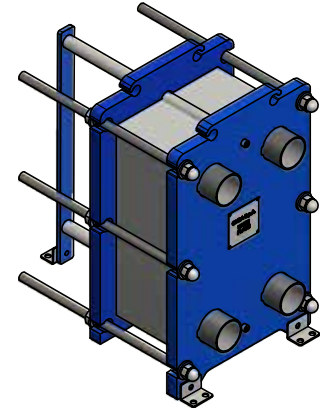
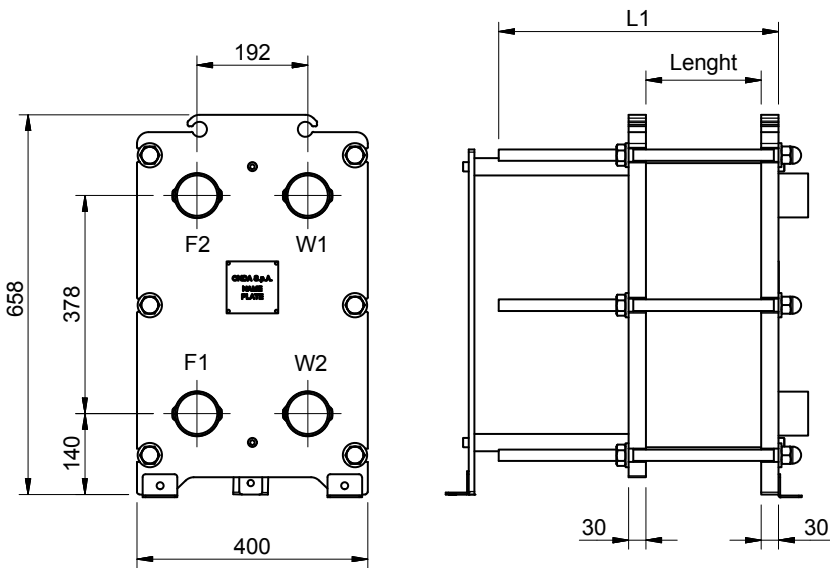

L1							
N° plate	0-25	26-50	51-75	76-100	101-150	151-200	201-250
GG008 (2,7)	330	500	750	750	1000	1000	NO

SPECIFICATIONS	GG008 PN10	GG008 PN16
PRESSURE RANGE (bar)	10	16
TEMPERATURE RANGE (°C) NBR	-10°C to +100°C	-10°C to +100°C
TEMPERATURE RANGE (°C) EPDM	-10°C to +120°C	-10°C to +120°C
MAXIMUM CONNECTIONS AVAILABLE (mm)	Ø 68mm	Ø 68mm
MAXIMUM FLOW RATE (m³/h)	72	72
VOLUME / CHANNEL (liters)	0,16	0,16
DIMENSIONS (mm)	400x658	400x658
LENGHT CALCULATION (mm)	N x 2,7	N x 2,7
WEIGHT CALCULATION (kg)	N x 0,6 + 120	N x 0,6 + 120

CONNECTIONS TYPE	
DN65	
2" 1/2 GAS	2" 1/2 NPT

- F1 INLET CIRCUIT 1
- F2 OUTLET CIRCUIT 1
- W1 INLET Secondary Fluid
- W2 OUTLET Secondary Fluid

Plate material AISI 304L / AISI 316L / TITANIUM
 Plate thickness 0,5mm
 Gasket material NBR / EPDM / VITON / HNBR / EPDM H HT
 Frame material P265GH CARBON STEEL
 Frame colour RAL 5002 SEMIGLOSS FINISHING
 Tie rod N° 6 M20 GALVANIZED CLASS 8.8
 Pressure PN 10 - PN16
 Material connections AISI 304 / AISI 316 / POM-C

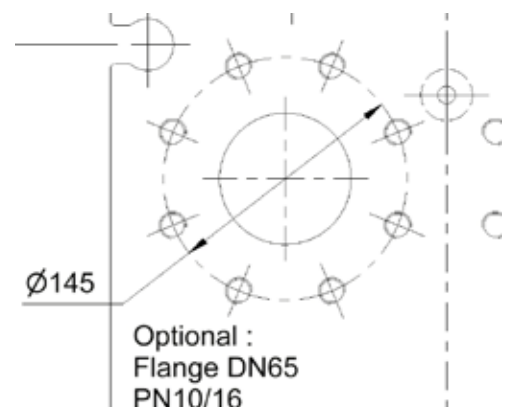

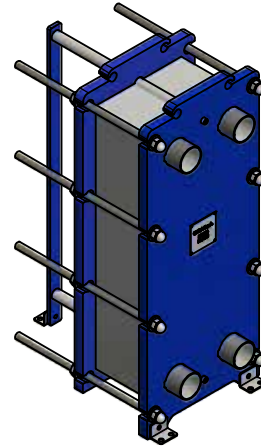
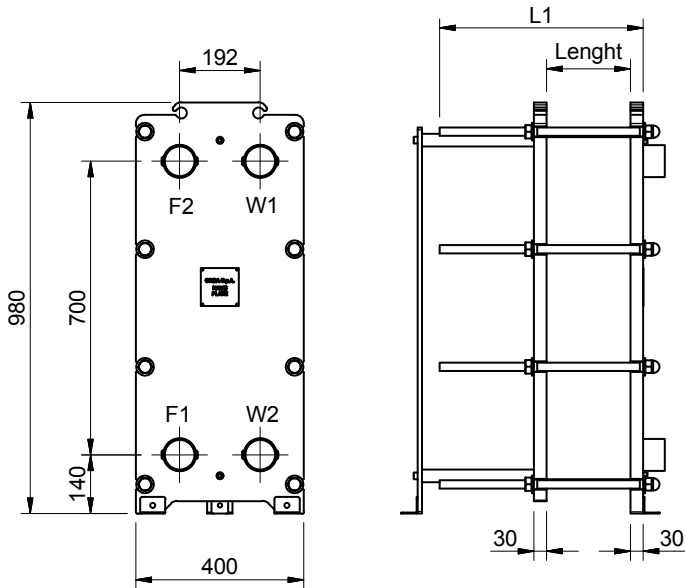

L1							
N° plate	0-25	26-50	51-75	76-100	101-150	151-200	201-250
GG009 (2,7)	330	500	750	750	1000	1000	NO

SPECIFICATIONS	GG009 PN10	GG009 PN16
PRESSURE RANGE (bar)	10	16
TEMPERATURE RANGE (°C) NBR	-10°C to +100°C	-10°C to +100°C
TEMPERATURE RANGE (°C) EPDM	-10°C to +120°C	-10°C to +120°C
MAXIMUM CONNECTIONS AVAILABLE (mm)	Ø 68mm	Ø 68mm
MAXIMUM FLOW RATE (m³/h)	72	72
VOLUME / CHANNEL (liters)	0,38	0,38
DIMENSIONS (mm)	400x980	400x980
LENGHT CALCULATION (mm)	N x 2,7	N x 2,7
WEIGHT CALCULATION (kg)	N x 1 + 184	N x 1 + 184

CONNECTIONS TYPE	
DN65	
2" 1/2 GAS	2" 1/2 NPT

- F1 INLET CIRCUIT 1
- F2 OUTLET CIRCUIT 1
- W1 INLET Secondary Fluid
- W2 OUTLET Secondary Fluid

Plate material AISI 304L / AISI 316L / TITANIUM
 Plate thickness 0,5mm
 Gasket material NBR / EPDM / VITON / HNBR / EPDM H HT
 Frame material P265GH CARBON STEEL
 Frame colour RAL 5002 SEMIGLOSS FINISHING
 Tie rod N° 8 M20 GALVANIZED CLASS 8.8
 Pressure PN 10 - PN16
 Material connections AISI 304 / AISI 316 / POM-C

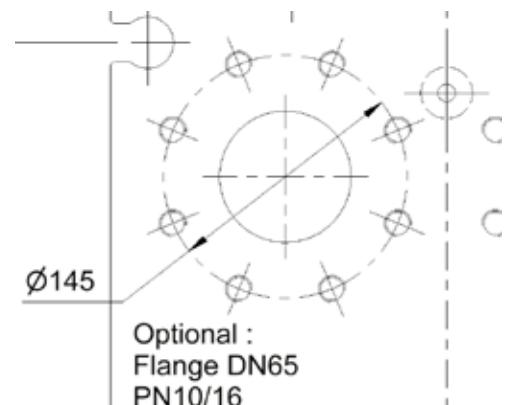

GG010

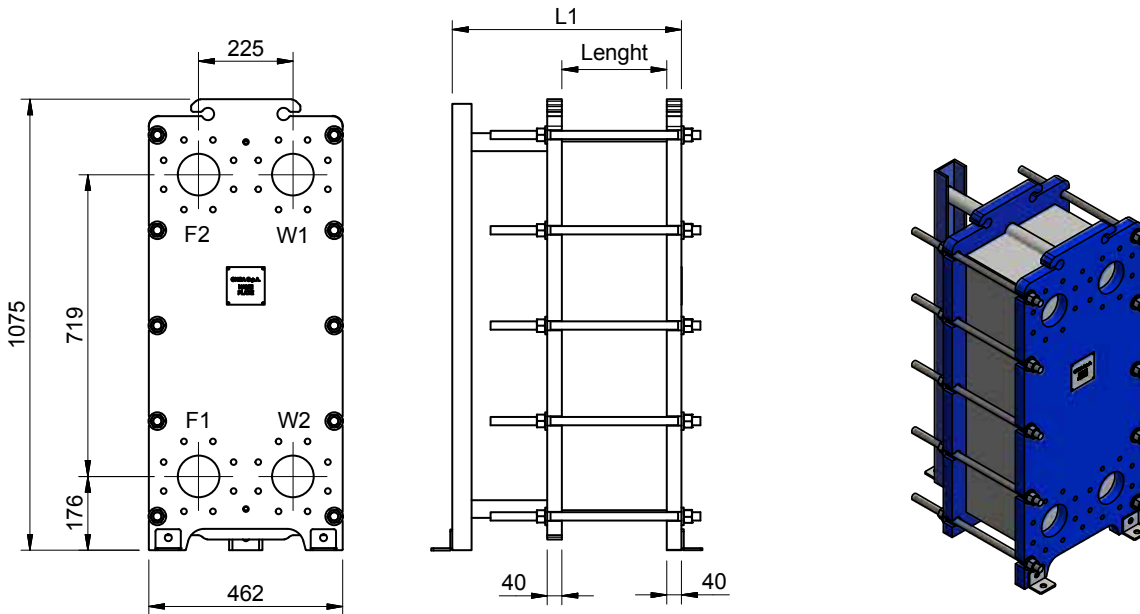

L1							
N° plate	0-25	26-50	51-75	76-100	101-150	151-200	201-250
GG010 (3,1)	500	500	750	750	1000	1500	1500

SPECIFICATIONS	GG010 PN10	GG010 PN16
PRESSURE RANGE (bar)	10	16
TEMPERATURE RANGE (°C) NBR	-10°C to +100°C	-10°C to +100°C
TEMPERATURE RANGE (°C) EPDM	-10°C to +120°C	-10°C to +120°C
MAXIMUM CONNECTIONS AVAILABLE (mm)	Ø 100mm	Ø 100mm
MAXIMUM FLOW RATE (m³/h)	150	150
VOLUME / CHANNEL (liters)	0,61	0,61
DIMENSIONS (mm)	462x1075	462x1075
LENGHT CALCULATION (mm)	N x 3,1	N x 3,1
WEIGHT CALCULATION (kg)	N x 1,3 + 264	N x 1,3 + 264

CONNECTIONS TYPE
DN100
4"

F1 INLET CIRCUIT 1
 F2 OUTLET CIRCUIT 1
 W1 INLET Secondary Fluid
 W2 OUTLET Secondary Fluid

Plate material AISI 304L / AISI 316L / TITANIUM
 Plate thickness 0,5mm
 Gasket material NBR / EPDM / VITON / HNBR / EPDM H HT
 Frame material P265GH CARBON STEEL
 Frame colour RAL 5002 SEMIGLOSS FINISHING
 Tie rod N° 10 M20 GALVANIZED CLASS 8.8
 Pressure PN 10 - PN16
 Connections FLANGES + GASKET (NBR/EPDM)

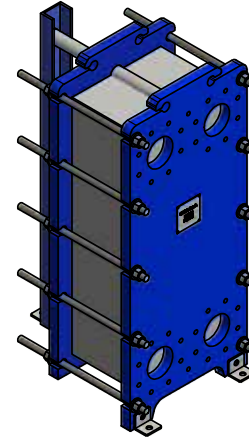
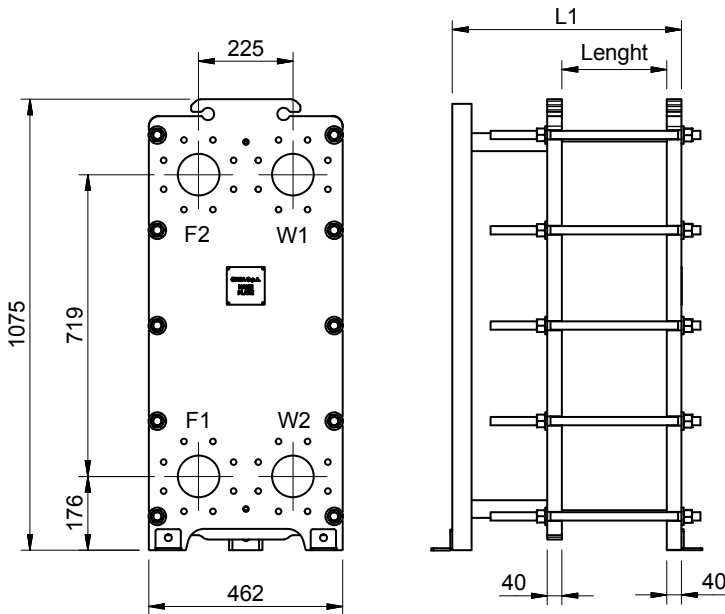

L1							
N° plate	0-25	26-50	51-75	76-100	101-150	151-200	201-250
GM010 (4,5)	500	750	1000	1000	1500	1500	NO

SPECIFICATIONS	GM010 PN10	GM010 PN16
PRESSURE RANGE (bar)	10	16
TEMPERATURE RANGE (°C) NBR	-10°C to +100°C	-10°C to +100°C
TEMPERATURE RANGE (°C) EPDM	-10°C to +120°C	-10°C to +120°C
MAXIMUM CONNECTIONS AVAILABLE (mm)	Ø 100mm	Ø 100mm
MAXIMUM FLOW RATE (m³/h)	150	150
VOLUME / CHANNEL (liters)	0,96	0,96
DIMENSIONS (mm)	462x1075	462x1075
LENGHT CALCULATION (mm)	N x 4,5	N x 4,5
WEIGHT CALCULATION (kg)	N x 1,35 + 264	N x 1,35 + 264

CONNECTIONS TYPE
DN100
4"

F1 INLET CIRCUIT 1
 F2 OUTLET CIRCUIT 1
 W1 INLET Secondary Fluid
 W2 OUTLET Secondary Fluid

Plate material AISI 304L / AISI 316L / TITANIUM
 Plate thickness 0,5mm
 Gasket material NBR / EPDM / VITON / HNBR / EPDM H HT
 Frame material P265GH CARBON STEEL
 Frame colour RAL 5002 SEMIGLOSS FINISHING
 Tie rod N° 10 M20 GALVANIZED CLASS 8.8
 Pressure PN 10 - PN16
 Connections FLANGES + GASKET (NBR/EPDM)

GT012

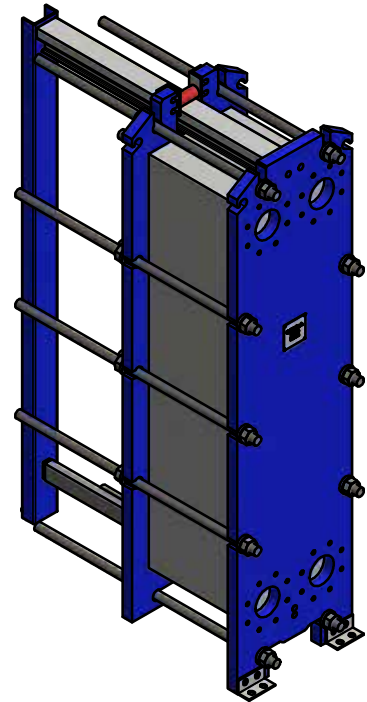
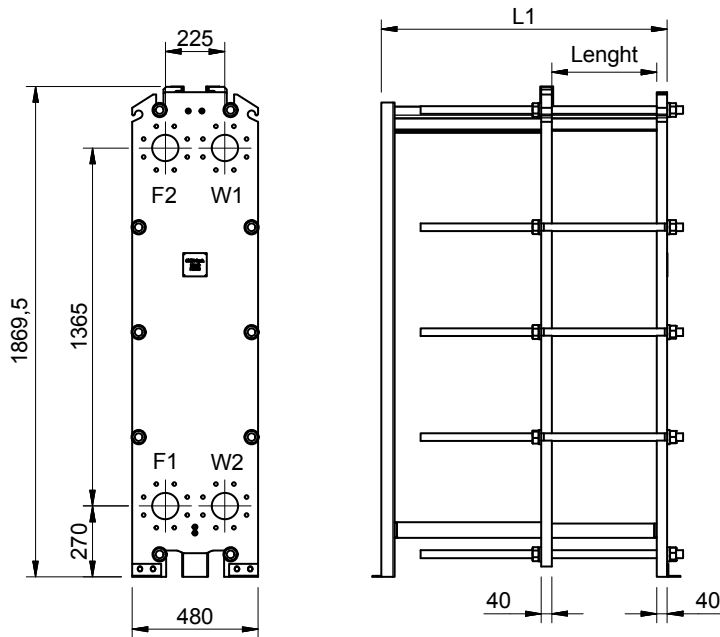

L1

N° plate	0-25	26-50	51-75	76-100	101-150	151-200	201-250	251-300
GT012 (3,1)	1000	1000	1000	1000	1000	1500	1500	1500

SPECIFICATIONS	GT012 PN10	GT012 PN16
PRESSURE RANGE (bar)	10	16
TEMPERATURE RANGE (°C) NBR	-10°C to +100°C	-10°C to +100°C
TEMPERATURE RANGE (°C) EPDM	-10°C to +120°C	-10°C to +120°C
MAXIMUM CONNECTIONS AVAILABLE (mm)	Ø 100mm	Ø 100mm
MAXIMUM FLOW RATE (m³/h)	150	150
VOLUME / CHANNEL (liters)	1,25	1,25
DIMENSIONS (mm)	480x1869	480x1869
LENGHT CALCULATION (mm)	N x 3,1	N x 3,1
WEIGHT CALCULATION (kg)	N x 2,2 + 580	N x 2,2 + 580

CONNECTIONS TYPE

DN100
4"

- F1 INLET CIRCUIT 1
- F2 OUTLET CIRCUIT 1
- W1 INLET Secondary Fluid
- W2 OUTLET Secondary Fluid

Plate material	AISI 304L / AISI 316L / TITANIUM
Plate thickness	0,5mm
Gasket material	NBR / EPDM / VITON / HNBR / EPDM H HT
Frame material	P265GH CARBON STEEL
Frame colour	RAL 5002 SEMIGLOSS FINISHING
Tie rod	N° 10 M30 GALVANIZED CLASS 8.8
Pressure	PN 10 - PN16
Connections	FLANGES + GASKET (NBR/EPDM)

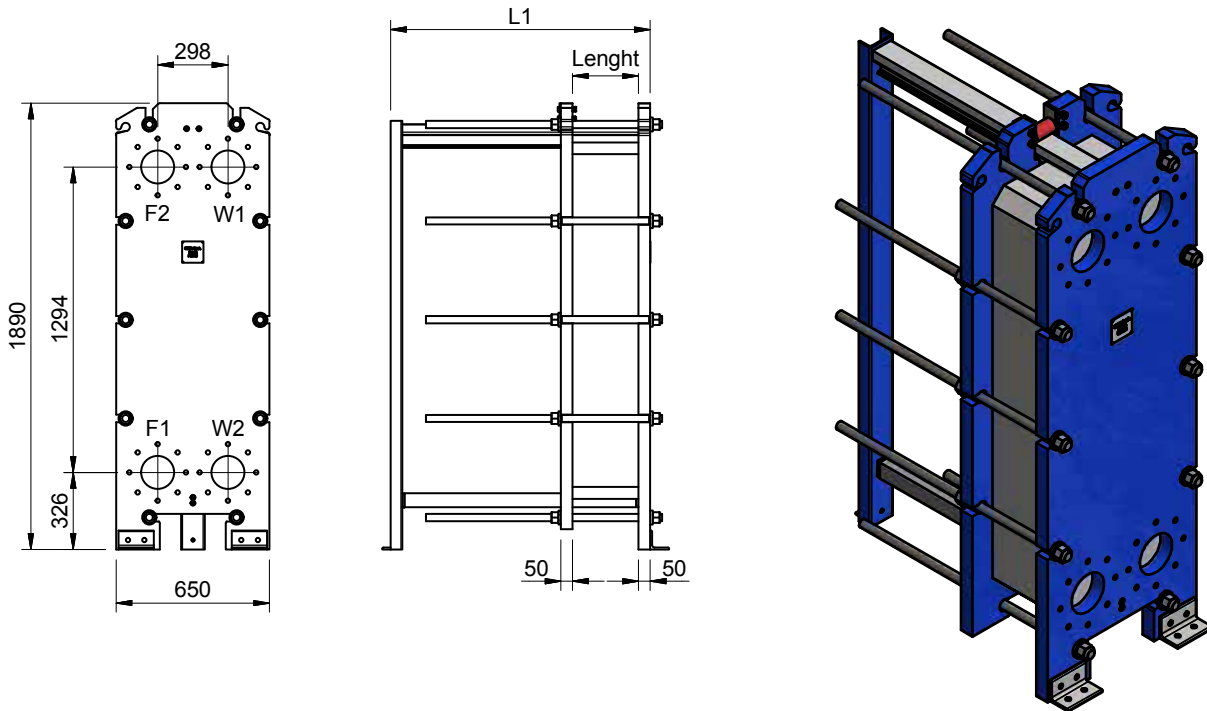

L1

N° plate	0-25	26-50	51-75	76-100	101-150	151-200	201-250	251-300	301-350
GT015 (3,1)	1000	1000	1000	1000	1000	1500	1500	1500	2000

SPECIFICATIONS	GT015 PN10	GT015 PN16
PRESSURE RANGE (bar)	10	16
TEMPERATURE RANGE (°C) NBR	-10°C to +100°C	-10°C to +100°C
TEMPERATURE RANGE (°C) EPDM	-10°C to +120°C	-10°C to +120°C
MAXIMUM CONNECTIONS AVAILABLE (mm)	Ø 148mm	Ø 148mm
MAXIMUM FLOW RATE (m³/h)	349	349
VOLUME / CHANNEL (liters)	1,52	1,52
DIMENSIONS (mm)	650X1890	650X1890
LENGHT CALCULATION (mm)	N x 3,1	N x 3,1
WEIGHT CALCULATION (kg)	N x 2,75 + 945	N x 2,75 + 945

CONNECTIONS TYPE
DN150
6"

- F1 INLET CIRCUIT 1
- F2 OUTLET CIRCUIT 1
- W1 INLET Secondary Fluid
- W2 OUTLET Secondary Fluid

Plate material	AISI 304L / AISI 316L / TITANIUM
Plate thickness	0,5mm
Gasket material	NBR / EPDM / VITON / HNBR / EPDM H HT
Frame material	P265GH CARBON STEEL
Frame colour	RAL 5002 SEMIGLOSS FINISHING
Tie rod	N° 10 M30 GALVANIZED CLASS 8.8
Pressure	PN 10 - PN16
Connections	FLANGES + GASKET (NBR/EPDM)

GP015

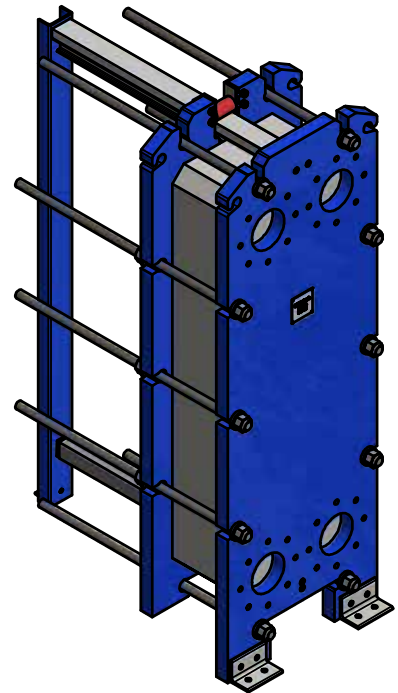
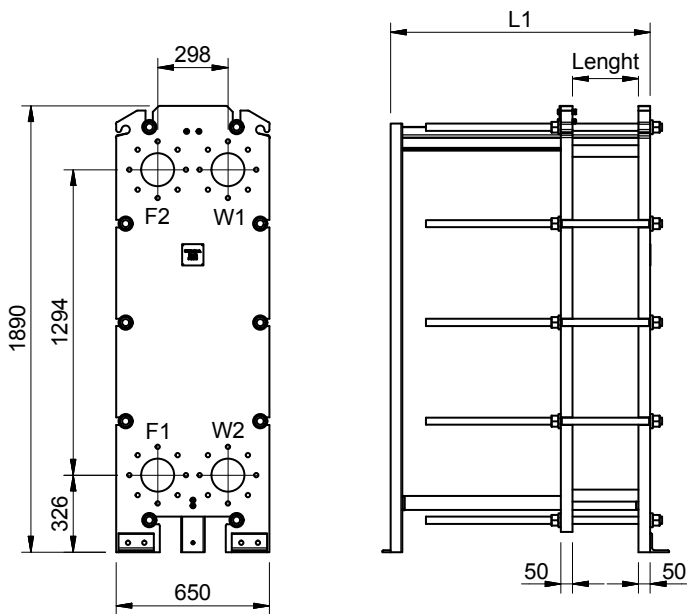

L1

N° plate	0-25	26-50	51-75	76-100	101-150	151-200	201-250	251-300	301-350
GP015 (4,3)	1000	1000	1000	1000	1500	1500	1500	2000	3000

SPECIFICATIONS	GP015 PN10	GP015 PN16
PRESSURE RANGE (bar)	10	16
TEMPERATURE RANGE (°C) NBR	-10°C to +100°C	-10°C to +100°C
TEMPERATURE RANGE (°C) EPDM	-10°C to +120°C	-10°C to +120°C
MAXIMUM CONNECTIONS AVAILABLE (mm)	Ø 148mm	Ø 148mm
MAXIMUM FLOW RATE (m³/h)	349	349
VOLUME / CHANNEL (liters)	2,48	2,48
DIMENSIONS (mm)	650X1890	650X1890
LENGHT CALCULATION (mm)	N x 4,3	N x 4,3
WEIGHT CALCULATION (kg)	N x 2,80 + 945	N x 2,80 + 945

CONNECTIONS TYPE

DN150
6"

- F1 INLET CIRCUIT 1
- F2 OUTLET CIRCUIT 1
- W1 INLET Secondary Fluid
- W2 OUTLET Secondary Fluid

Plate material	AISI 304L / AISI 316L / TITANIUM
Plate thickness	0,5mm
Gasket material	NBR / EPDM / VITON / HNBR / EPDM H HT
Frame material	P265GH CARBON STEEL
Frame colour	RAL 5002 SEMIGLOSS FINISHING
Tie rod	N° 10 M30 GALVANIZED CLASS 8.8
Pressure	PN 10 - PN16
Connections	FLANGES + GASKET (NBR/EPDM)

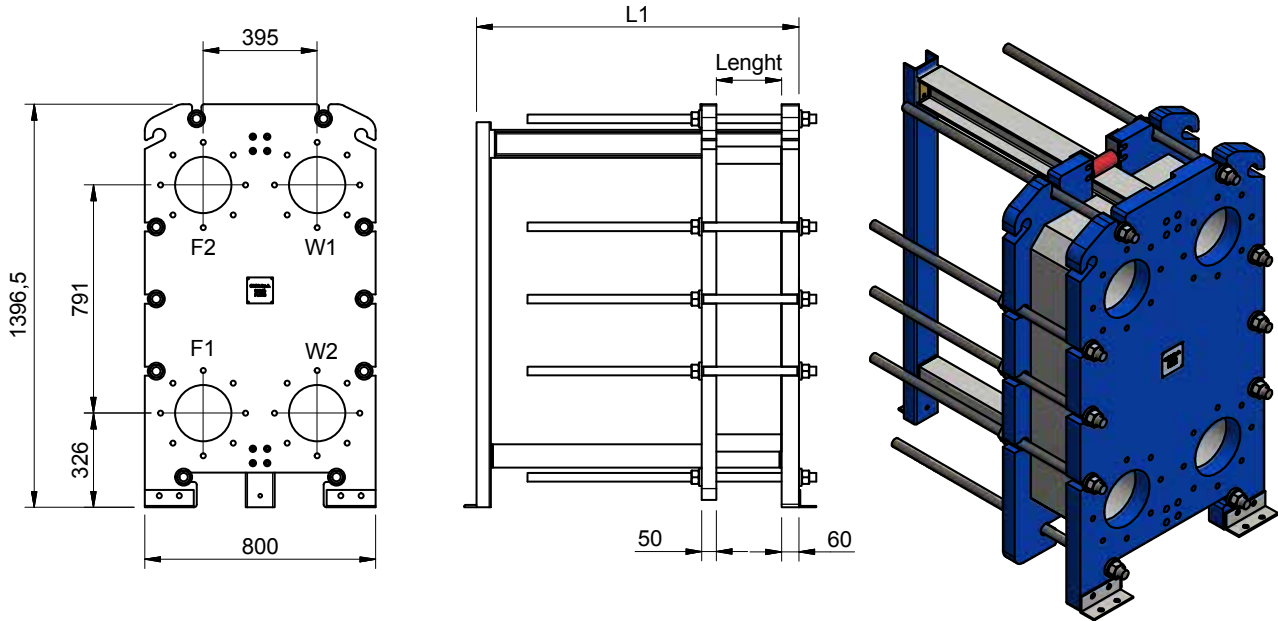

L1

N° plate	0-25	26-50	51-75	76-100	101-150	151-200	201-250	250-300	301-350	351-400	401-450
GT021 (3,1)	1000	1000	1000	1000	1000	1500	1500	1500	2000	3000	3000

SPECIFICATIONS	GT021 PN10	GT021 PN16
PRESSURE RANGE (bar)	10	16
TEMPERATURE RANGE (°C) NBR	-10°C to +100°C	-10°C to +100°C
TEMPERATURE RANGE (°C) EPDM	-10°C to +120°C	-10°C to +120°C
MAXIMUM CONNECTIONS AVAILABLE (mm)	Ø 200mm	Ø 200mm
MAXIMUM FLOW RATE (m³/h)	600	600
VOLUME / CHANNEL (liters)	1,15	1,15
DIMENSIONS (mm)	800x1396	800x1396
LENGHT CALCULATION (mm)	N x 3,15	N x 3,15
WEIGHT CALCULATION (kg)	N x 2,35 + 900	N x 2,35 + 900

CONNECTIONS TYPE
DN200
8"

- F1 INLET CIRCUIT 1
- F2 OUTLET CIRCUIT 1
- W1 INLET Secondary Fluid
- W2 OUTLET Secondary Fluid

Plate material	AISI 304L / AISI 316L / TITANIUM
Plate thickness	0,5mm
Gasket material	NBR / EPDM / VITON / HNBR / EPDM H HT
Frame material	P265GH CARBON STEEL
Frame colour	RAL 5002 SEMIGLOSS FINISHING
Tie rod	N° 10 M30 GALVANIZED CLASS 8.8
Pressure	PN 10 - PN16
Connections	FLANGES

GT022

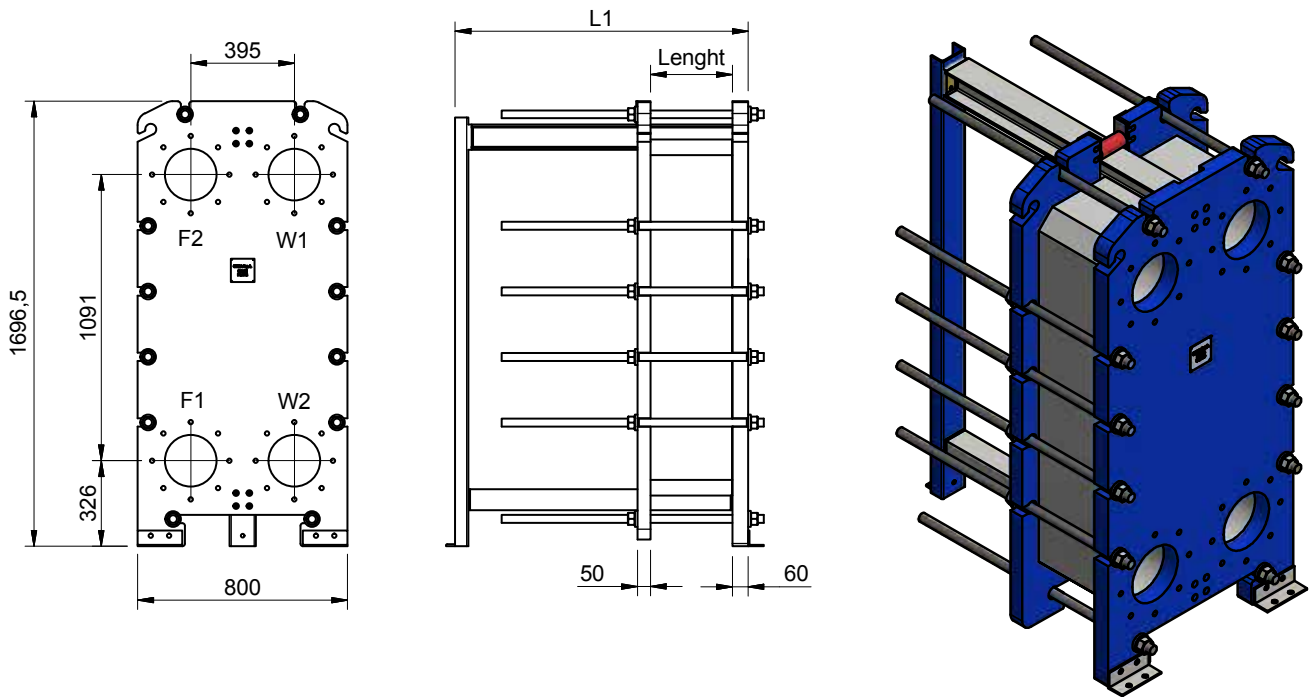

L1											
N° plate	0-25	26-50	51-75	76-100	101-150	151-200	201-250	250-300	301-350	351-400	401-450
GT022 (3,1)	1000	1000	1000	1000	1000	1500	1500	1500	2000	3000	3000

SPECIFICATIONS	GT022 PN10	GT022 PN16
PRESSURE RANGE (bar)	10	16
TEMPERATURE RANGE (°C) NBR	-10°C to +100°C	-10°C to +100°C
TEMPERATURE RANGE (°C) EPDM	-10°C to +120°C	-10°C to +120°C
MAXIMUM CONNECTIONS AVAILABLE (mm)	Ø 200mm	Ø 200mm
MAXIMUM FLOW RATE (m³/h)	600	600
VOLUME / CHANNEL (liters)	1,68	1,68
DIMENSIONS (mm)	800x1696	800x1696
LENGHT CALCULATION (mm)	N x 3,15	N x 3,15
WEIGHT CALCULATION (kg)	N x 3,15 + 1120	N x 3,15 + 1120

CONNECTIONS TYPE
DN200
8"

- F1 INLET CIRCUIT 1
- F2 OUTLET CIRCUIT 1
- W1 INLET Secondary Fluid
- W2 OUTLET Secondary Fluid

Plate material	AISI 304L / AISI 316L / TITANIUM
Plate thickness	0,5mm
Gasket material	NBR / EPDM / VITON / HNBR / EPDM H HT
Frame material	P265GH CARBON STEEL
Frame colour	RAL 5002 SEMIGLOSS FINISHING
Tie rod	N° 12 M30 GALVANIZED CLASS 8.8
Pressure	PN 10 - PN16
Connections	FLANGES

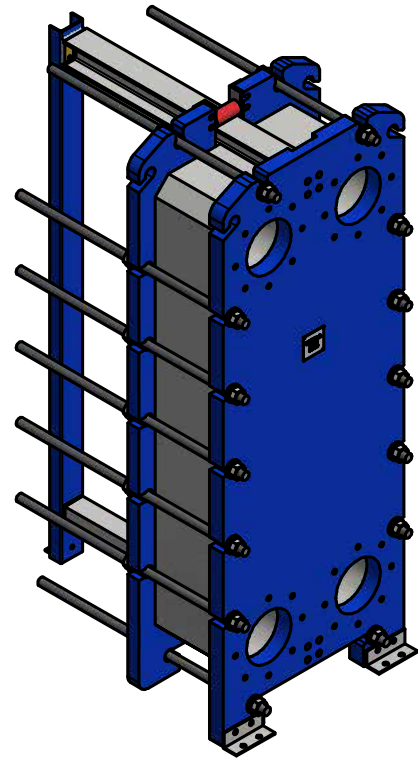
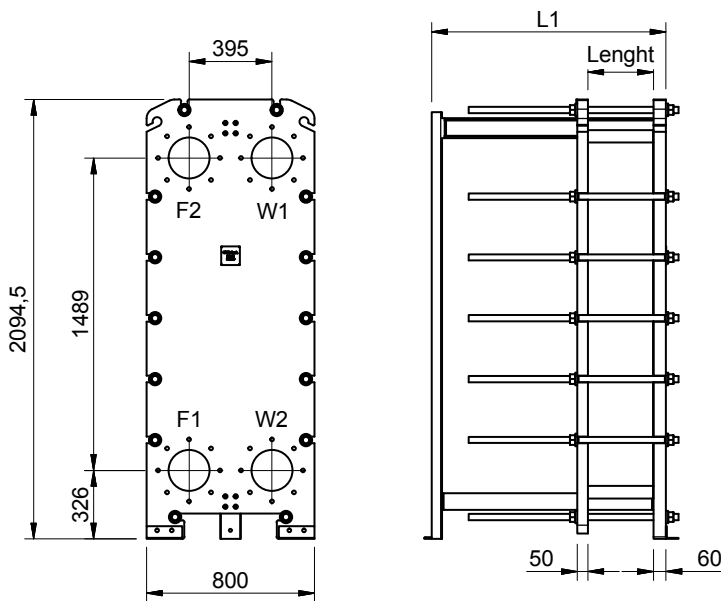

L1

N° plate	0-25	26-50	51-75	76-100	101-150	151-200	201-250	250-300	301-350	351-400	401-450
GT025 (3,1)	1000	1000	1000	1000	1000	1500	1500	1500	2000	3000	3000

SPECIFICATIONS	GT025 PN10	GT025 PN16
PRESSURE RANGE (bar)	10	16
TEMPERATURE RANGE (°C) NBR	-10°C to +100°C	-10°C to +100°C
TEMPERATURE RANGE (°C) EPDM	-10°C to +120°C	-10°C to +120°C
MAXIMUM CONNECTIONS AVAILABLE (mm)	Ø 200mm	Ø 200mm
MAXIMUM FLOW RATE (m³/h)	600	600
VOLUME / CHANNEL (liters)	2,6	2,6
DIMENSIONS (mm)	800x2094	800x2094
LENGHT CALCULATION (mm)	N x 3,15	N x 3,15
WEIGHT CALCULATION (kg)	N x 4,60 + 1420	N x 4,60 + 1420

CONNECTIONS TYPE
DN200
8"

- F1 INLET CIRCUIT 1
- F2 OUTLET CIRCUIT 1
- W1 INLET Secondary Fluid
- W2 OUTLET Secondary Fluid

Plate material	AISI 304L / AISI 316L / TITANIUM
Plate thickness	0,5mm
Gasket material	NBR / EPDM / VITON / HNBR / EPDM H HT
Frame material	P265GH CARBON STEEL
Frame colour	RAL 5002 SEMIGLOSS FINISHING
Tie rod	N° 14 M30 GALVANIZED CLASS 8.8
Pressure	PN 10 - PN16
Connections	FLANGES

Optional :

Coibentazione
(Insulation)

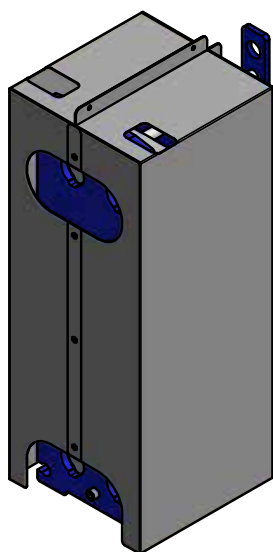

Configurazione 2 passi
(2 passes configuration)

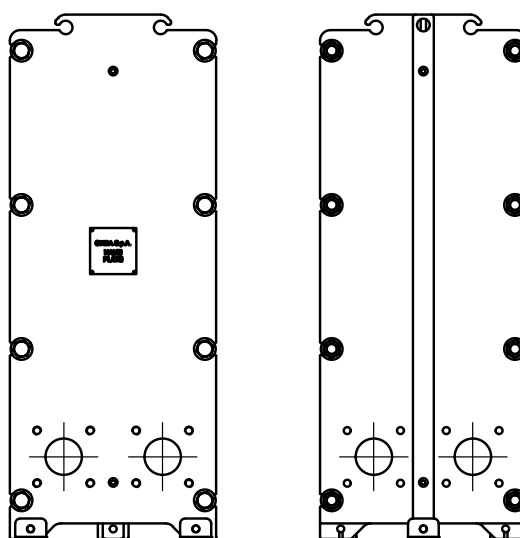

Connessioni speciali a richiesta ove possibile
(Special connections if possible)

Collare in gomma
(Rubber connections)

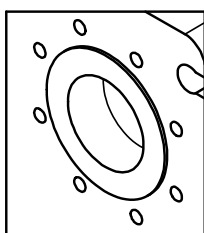

Collare Aisi 316L
(Aisi 316 collar)

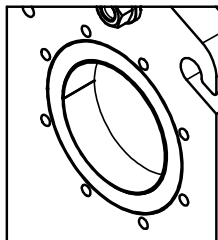

Flangiato
(Flanged)

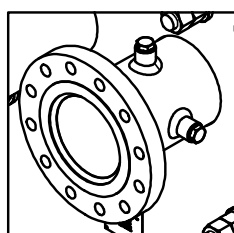

Victaulic

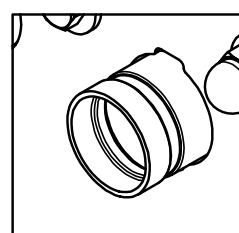

PVC (Incollaggio)

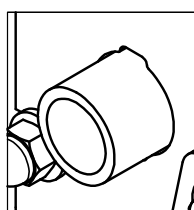

PVC (Filettato M)

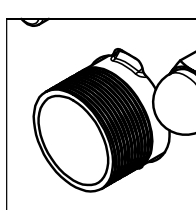

PVC (Filettato F)

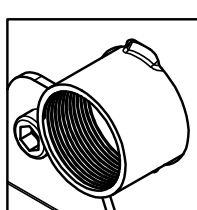

Attacco Clamp ISO
Aisi 316 L

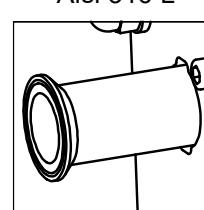

GARANZIA

A - Onda S.p.A. garantisce l'assenza di vizi e difetti nella lavorazione e nei materiali nei Prodotti per 18 mesi dalla data della consegna.

Pertanto ove, durante il periodo di garanzia, i contestati difetti dei Prodotti risultino oggettivamente fondati e siano riconosciuti per iscritto da Onda S.p.A., quest'ultima provvederà gratuitamente alla riparazione o, a sua discrezione, alla sostituzione dei Prodotti difettosi, con consegna effettuata franco fabbrica (Ex Works – Incoterms 2000) Stabilimento di Onda S.p.A. in Via Lord Baden Powell, 11 – 36045 Lonigo (VI).

B - Pena di decadenza dalla garanzia, il Cliente dovrà denunciare per iscritto, a mezzo raccomandata con ricevuta di ritorno, i vizi o i difetti riscontrati entro e non oltre 10 (dieci) giorni dal ricevimento dei Prodotti o evidenziati dalla messa in funzione dell'impianto, oppure, trattandosi di vizi e/o difetti occulti, entro e non oltre 10 (dieci) giorni dalla scoperta degli stessi. In questo caso, l'onere della prova della data della scoperta graverà sul Cliente.

C - Onda S.p.A. garantisce inoltre che i Prodotti sono fabbricati in conformità alle leggi italiane e alle normative comunitarie vigenti alla data di conferma da parte di Onda S.p.A. del relativo ordine del Cliente.

Salvo diverso accordo scritto tra le parti, tutte le altre spese accessorie agli interventi di sostituzione e/o di riparazione, saranno a carico e a rischio del Cliente.

D - La garanzia è esclusa qualora i vizi o difetti dei Prodotti siano stati determinati dalle seguenti cause:

- Naturale usura e deterioramento.
- Riparazioni, manomissioni o modifiche non autorizzate.
- Uso e applicazione impropri.
- Eccessiva sollecitazione termica, anche occasionale.
- Eccessiva sollecitazione elettrica o meccanica.
- Mancato rispetto dei parametri funzionali e ambientali indicati da Onda S.p.A. per il corretto impiego e funzionamento dei Prodotti.
- Installazione dei Prodotti difforme da quella indicate nelle specifiche tecniche fornite da Onda S.p.A.
- Mancata messa a terra dello scambiatore.
- Qualsiasi altra causa imputabile a negligenza del Cliente.

E - La garanzia è inoltre esclusa in caso di:

- Eventuale non conformità dei Prodotti a normative italiane e/o comunitarie entrate in vigore dopo la data della trasmissione della conferma d'ordine di Onda S.p.A.;
- Eventuale non conformità dei Prodotti a leggi e/o normative in vigore nel luogo in cui i Prodotti sono installati e/o assemblati dal Cliente e/o nel luogo di finale utilizzazione dei Prodotti, qualora il Cliente non abbia espressamente richiesto la conformità dei Prodotti a tali leggi e/o normative e non abbia regolarmente informato ONDA S.p.A. del loro contenuto prima della data di trasmissione della conferma d'ordine di quest'ultima. Resta inteso che la presente limitazione si intende efficace anche con riferimento a specifiche normative vigenti in Stati dell'Unione Europea ed applicabili in via autonoma rispetto alle normative comunitarie.

F - Il Cliente non dovrà vendere o commercializzare Prodotti non conformi alle leggi e/o normative indicate nella precedente lettera E. In caso contrario, il Cliente manleverà ONDA S.p.A. da ogni danno e/o perdita dalla stessa sofferto in seguito a contestazioni, sollevate in via giudiziale o stragiudiziale, da qualsiasi soggetto terzo o da pubblica autorità in conseguenza della fabbricazione da parte di ONDA S.p.A. di prodotti non conformi alle summenzionate leggi e/o normative.

G - Ferma restando l'applicazione del DPR 224/1988, in materia di responsabilità per danno da prodotti difettosi, e la responsabilità di Onda S.p.A. in caso di dolo o colpa grave, quest'ultima non sarà in alcun caso responsabile per i danni diretti, indiretti o incidentali che dovessero in qualsiasi modo derivare dalla difettosità dei Prodotti.

WARRANTY

A - Onda S.p.A. warrants that the Products shall be free from defects in material and workmanship for a period of 18 months from the date of the delivery.

Therefore, should Onda S.p.A., within the warranty period, acknowledge and recognise in writing the existence of the defects in the products and said defects be materially grounded, Onda S.p.A. shall, at its discretion, repair the defective Products at no costs for the Client or replace them by delivering the substitutive products Ex works (Incoterms 2000) at Onda S.p.A.'s premises (Via Lord Baden Powell, 11 – 36045 Lonigo (VI) – Italy).

B - Subject to loss of the warranty, notice of any defect shall be given by the Client in writing with return receipt registered letter within, and not later than, 10 (ten) days from the date of receipt of the products or from the start up of the plant. Subject to loss of the warranty, notice of any latent defect of the Products by the Client shall be given in writing, by return receipt registered letter, within and not later than 10 (ten) days from the date of the relevant discovery. It is hereby understood that the burden of the proof of the date of the discovery shall be borne by the Client.

C - Onda S.p.A. also warrants that the Products are manufactured in compliance with the Italian and European Laws and Regulations in force on the date of the confirmation by Onda S.p.A. of the relevant Client's order. Unless otherwise expressly agreed in writings by the parties, Client shall bear any other additional expenses related to the operations of repairing or replacing of the defective products.

D - This warranty shall not apply should the defects of the Products be caused by:

- Natural wear and tear.
- Unauthorised repairs, interventions or modifications.
- Unsuitable use or application.
- Thermal overexposure, also when occasional.
- Electrical or mechanical over-stress.
- Failure of respecting the functional and environmental parameters suggested by Onda S.p.A. for the correct use and exploitation of the products.
- Installation of the products not in compliance with the technical specifications provided by Onda S.p.A.
- Missing earth grounding.
- Any other cause due to the Client's negligence.

E - This warranty shall also not apply in case of:

- Non compliance of the Products with Italian and European Laws and/or Regulations entered in force after the date of transmission of the order confirmation by Onda S.p.A.
- Non compliance of the Products with Laws and/or Regulations in force in the place where the Products are installed and/or assembled by the Client and/or in the place of their final use, should the Client not expressly require the conformity of the Products to said Laws and Regulations and not duly inform Onda S.p.A. of their content before the date of transmission of the latter's order confirmation. This limitation of the warranty is also applicable with reference to peculiar Laws and Regulations valid and binding in States of the European Union independently of the European Laws and Regulations.

F - The Client shall not sell or market Products not in compliance with the Laws and Regulations mentioned under letter E above. In the negative, the Client shall keep ONDA S.p.A. harmless of any damage or loss suffered by the latter, due to any third party's and/or authority's claim raised as a consequence of the manufacture by ONDA S.p.A. of Products not in compliance with the above mentioned Laws and Regulations.

G - Without prejudice to the application of DPR 224/1988 on product liability and liability for gross negligence or wilful misconduct, Onda S.p.A. shall never be liable for direct, indirect or occasional damages which in any manner derived from defective products.



ONDA S.p.A.

onda@onda-it.com
www.onda-it.com

PLANT 1 Headquarters

Via Dante Alighieri, 27B
36065 Mussolente (VI)
Italy
t. +39 0424 87633

PLANT 2

Via L. Baden Powell, 11
36045 Lonigo (VI)
Italy
t. +39 0444 720720

PLANT 3

Via Vittoria, 158A
36065 Mussolente (VI)
Italy
t. +39 0424 87506

PLANT 4

Onda USA L.L.C.
600 London Rd
Delaware, OH 43015
t. +1 614 321 3342

Onda France S.A.R.L.

320, Avenue Berthelot
69008 Lyon France
t. +33 472784606
m. +33 608341000
www.onda-fr.com
onda@onda-fr.com

Onda USA L.L.C.

600 London Rd
Delaware, OH 43015
t. +1 614 321 3342
www.onda-us.com
onda@onda-us.com

Onda RU

Mayakovskogo Street, 18a, Khimki,
Moscow Region, Russia 141402
t. +7 495 971 88 53
m. +7 916 676 16 54
www.onda-it.com
info@onda-ru.com

Onda Nordic OY

Lentolantie 22
36220 Kangasala Tampere, Finland
t. +35 8331437300
m. +35 8409012999
www.wttgroup.fi
pasi.makinen@wttgroup.fi

Onda Shanghai

Heat Exchanger Co., Ltd.
瓊蕙啞（上海）热交换有限公司
Shanghai, Changning District,
Anhua Road 492, Building 1 Tower A, Room 126
上海市长宁区安化路492号1幢（A座）126室A092
t. +86 021 6056 4838 (ext.1000)
m. +33 6 08 34 10 00